

INSTALLATION AND MAINTENANCE INSTRUCTIONS

5251BPI and 5251RBPI Intelligent Plug-in Heat Sensors



156-1964-10CP

SPECIFICATIONS

Diameter:	104 mm installed in B501
Height:	51 mm
Weight:	137 g
Installation Temperature:	-10°C to 50°C
Operating Humidity Range:	10% to 93% Relative Humidity, Non-condensing
Voltage Range:	15 to 32 Volts DC Peak
Max. Standby Current:	300µA @ 24 VDC (one communication every 5 seconds with LED blink enabled)
LED Current:	6.5 mA @ 24 VDC
Fixed Temperature Rating:	63°C
Rate-of-Rise Detection:	Responds to greater than 8.3°C/minute; 5251RBPI

BEFORE INSTALLING

This sensor must be connected to a compatible Pertronic Industries C.I.E. in accordance with the system installation manual. The installation must meet the requirements of the Authority Having Jurisdiction (AHJ). Heat sensors offer maximum performance when installed in compliance with the AS1670.1-2004 or NZS4512.

Please refer to the C.I.E. operators manual for specific settings and operation of the 5251BPI and 5251RBPI

GENERAL DESCRIPTION

Models 5251BPI and 5251RBPI are intelligent heat sensors that utilize an advanced thermistor sensing circuit for fast response. All heat detectors should be spaced and installed in accordance with the requirements of the relevant authority having jurisdiction.

Model 5251BPI is a Type B fixed temperature heat sensor with 63.1°C fixed temperature alarm. Model 5251RBPI is a Type A rate-of-rise temperature heat sensor with 63.1°C fixed temperature alarm.

Two LEDs light to provide 360° visibility of the sensor indication. The LEDs can be latched ON by code command from the panel for an alarm indication. The LEDs can also be unlatched to the normal condition by code command. Remote LED annunciator capability is available as an optional accessory (Part No. RA400Z).

Models 5251BPI and 5251RBPI require compatible addressable communications to function properly. Connect these heat sensors to listed and compatible Pertronic Industries control panels (C.I.E.) only.

WIRING GUIDE

All wiring must be installed in compliance with the National Electrical Code, applicable local codes and the Authority Having Jurisdiction. Proper wire gauges should be used. The installation wires should be color coded to limit wiring mistakes and ease system troubleshooting. Improper connections will prevent a system from responding properly in the event of a fire.

Remove power from the communication line before installing sensors.

1. Wire the sensor base (supplied separately) per the wiring diagram, Figure 1.
2. Set the desired address on the sensor address switches, see Figure 2.
3. Install the sensor into the sensor base. Push the sensor into the base while turning it clockwise to secure it in place.
4. After all sensors have been installed, apply power to the control unit and activate the communication line.
5. Test the sensor(s) as described in the **TESTING** section of this manual.

FIGURE 1. WIRING DIAGRAM:

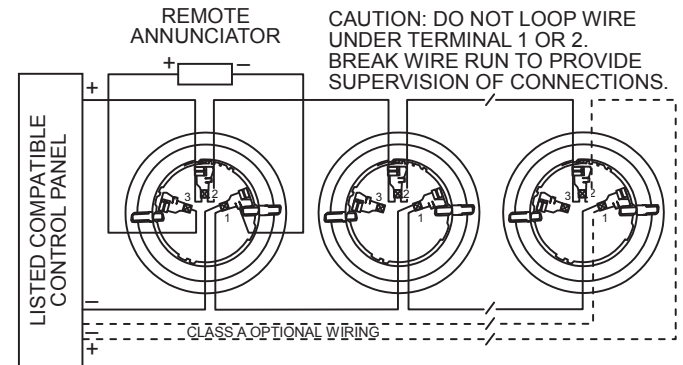

C1010-00

FIGURE 2:

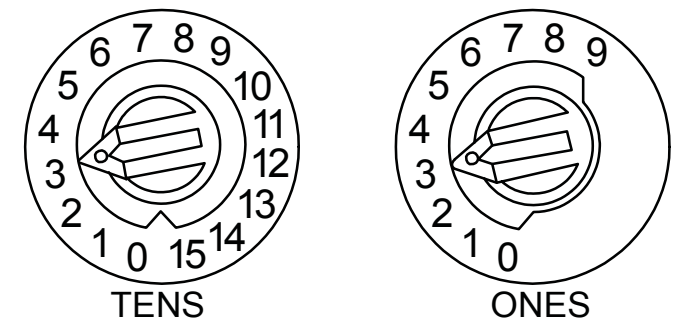

C0162-00

TAMPER RESISTANCE

The sensor bases have a tamper-resistant capability. When this capability is enabled, sensors cannot be removed from the base without the use of a small screwdriver or other similar tool. Refer to the sensor base installation instruction manual for details in using this capability.

TESTING

Before testing, notify the proper authorities that the system is undergoing maintenance, and will temporarily be out of service. Disable the system to prevent unwanted alarms.

All sensors must be tested after installation and periodically thereafter. Testing methods must satisfy the Authority Having Jurisdiction (AHJ). Sensors offer maximum performance when tested and maintained in compliance with AS1670.1-2004 or NZS4512.

A. Test Magnet (Model No. M02-09-00)

1. Place the test magnet against the cover in the magnet test area, as shown in Figure 3, to activate the test feature.
2. The LEDs should latch on within 10 seconds, indicating alarm and annunciating the panel.
3. Reset the detector at the system control panel.

B. Direct Heat Method (Hair dryer of 1000 – 1500 watts)

1. From the side of the detector, direct the heat toward the sensor. Hold the heat source about 15cm (6 inches) away to prevent damage to the cover during testing.
2. The LEDs on the detector should light when the temperature at the detector reaches the alarm setpoint. If the LEDs fail to light, check the power to the detector and the wiring in the detector base.
3. Reset the detector at the system control panel.

Detectors that fail these tests should be cleaned as described under **MAINTENANCE** and retested. If the detectors still fail these tests, they should be returned for repair.

FIGURE 3. VIEWS SHOWING POSITION OF TEST MAGNET:

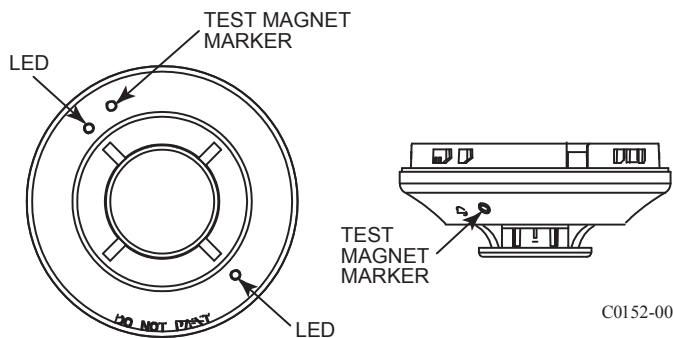

MAINTENANCE

NOTE: Before cleaning notify the proper authorities that the system is undergoing maintenance, and therefore the system will temporarily be out of service. Disable the loop or system undergoing maintenance to prevent unwanted alarms.

It is recommended that the sensor be removed from its mounting base for easier cleaning and that sensors be cleaned at least once a year. Use a vacuum cleaner to remove dust from the sensing chamber.

FIGURE 4:

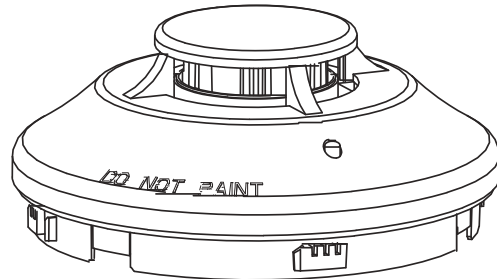

C0151-00



Please refer to insert for the Limitations of Fire Alarm Systems

THREE-YEAR LIMITED WARRANTY

Pertronic Industries warrants its enclosed enclosed thermal to be free from defects in materials and workmanship under normal use and service for a period of three years from date of manufacture. Pertronic Industries makes no other express warranty for this enclosed thermal. No agent, representative, dealer, or employee of the Company has the authority to increase or alter the obligations or limitations of this Warranty. The Company's obligation of this Warranty shall be limited to the repair or replacement of any part of the enclosed thermal which is found to be defective in materials or workmanship under normal use and service during the three year period commencing with the date of manufacture. After contacting your local Pertronic Industries representative for issuing a Return Authorization number (RA#) and arrange for return

return of the defective units. Please include a note describing the malfunction and suspected cause of failure. The Company shall not be obligated to repair or replace units which are found to be defective because of damage, unreasonable use, modifications, or alterations occurring after the date of manufacture. In no case shall the Company be liable for any consequential or incidental damages for breach of this or any other Warranty, expressed or implied whatsoever, even if the loss or damage is caused by the Company's negligence or fault. Some states do not allow the exclusion or limitation of incidental or consequential damages, so the above limitation or exclusion may not apply to you. This Warranty gives you specific legal rights, and you may also have other rights which vary from state to state.

FCC STATEMENT

This device complies with part 15 of the FCC Rules. Operation is subject to the following two conditions: (1) This device may not cause harmful interference, and (2) this device must accept any interference received, including interference that may cause undesired operation.

NOTE: This equipment has been tested and found to comply with the limits for a Class B digital device, pursuant to Part 15 of the FCC Rules. These limits are designed to provide reasonable protection against harmful interference in a residential installation. This equipment generates, uses and can radiate radio frequency energy and, if not installed and used in accordance with the instructions, may cause harmful interference to radio communications. However, there is no guarantee that interference will not occur in a particular installation. If this equipment does cause harmful interference to radio or television reception, which can be determined by turning the equipment off and on, the user is encouraged to try to correct the interference by one or more of the following measures:

- Reorient or relocate the receiving antenna.
- Increase the separation between the equipment and receiver.
- Connect the equipment into an outlet on a circuit different from that to which the receiver is connected.
- Consult the dealer or an experienced radio/TV technician for help.