



Zonal Sounder Board (Bell Monitor Board)

Head Office

Wellington

PO Box 35-063
Naenae
17 Eastern Hutt Rd
Wingate
Lower Hutt
Tel (04) 567-3229
Fax (04) 567-3644

www.pertronic.co.nz

sales@pertronic.co.nz
tech@pertronic.co.nz

Auckland Office

PO Box 15-867
New Lynn
119 Lansford Cres
Avondale
Auckland
Tel (09) 820-8228
Fax (09) 820-8284



ISO 9001: 2000

International Standards
Certifications
QAC/R61/0051

Product Overview:

The Pertronic **Zonal Sounder Board** (also referred to as the **Bell Monitor Board**) is used to allow one or more monitored sounder circuits to be activated independently for either Evacuation or Alert tones.

Single (1-way) and Quad (4-way) bell driver boards are available.

Other combinations may be constructed by interconnecting the externally accessible bussed control signals.

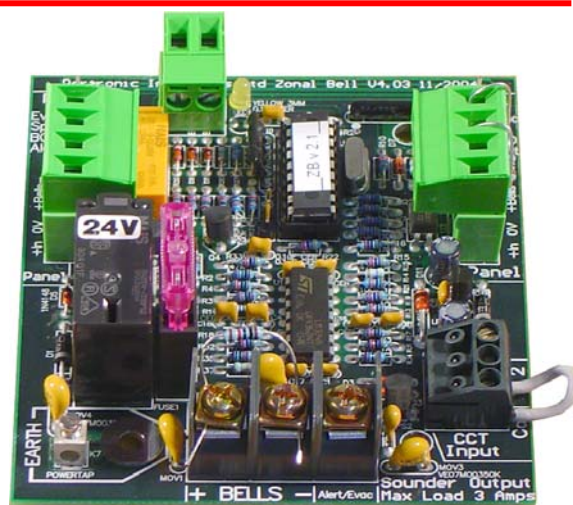

Specifications:

Dimensions: L x W x Dmm	95 x 85 x 30 320 x 96 x 30	- 1-way board - 4-way board
Power Supply: Quiescent:	12 or 24Vdc, <35mA <140mA	- 1-way board, sounder circuit inactive - 4-way board, sounder circuits inactive
		Add up to 3A per Sounder Circuit when active

Bussed Control Signals:

Panel Bells	- connected to the panel's monitored Bell output. - action depends on the state of other control signals. - active when the panel bell circuit is operated.
Evacuation	- usually connected to the panel Evacuation switch. - always activates the Sounder Circuit.
Sprinkler	- active when pulled low (0V), or taken high ($\geq 5V$). - follows the panel sprinkler input. - activates the Sounder Circuit if Panel Bells is active.
Bell Silence	- active when pulled low (0V). - disables the Sounder Circuit. - is overridden by Evacuation or Sprinkler.
Alert Control	- active when pulled low (0V). - used to generate a global alert signal - action depends on the state of other control signals. - active when pulled low (0V).

Independent Control Signals:

Circuit 1, 2	- activated by zones or one member of a group of detectors or Call-Points being in alarm. - action depends on the state of other control signals. - active when pulled low (0V).
Alert Link	- when inserted, disables the Alert Control signal - the global Alert state is disabled.

Output Functions:

Sounder Circuit	3A (fused) drive capability, 12Vdc or 24Vdc. - monitored with 10k Ω , 0.5W, 5% EOL Resistor (single spur) Evacuation: Continual activation. Alert: 4 seconds ON, 12 seconds OFF
Evac/Alert Control	'Third wire' for sounder Evacuation or Alert control. - pulled low (0V) for Alert.
Bells Defect	- the Sounder Circuit is monitored for a 10k Ω EOL resistor by applying reverse supply voltage to the circuit. - Defects in the bell circuit are sent to the panel by unbalancing the Panel Bells circuit.
LED Indication	ON steady Sounder Circuit relay ON. Flashing Latched fault ON: Sounder Circuit, Low battery or Bell circuit fault.

Connection Diagram : Single Unit

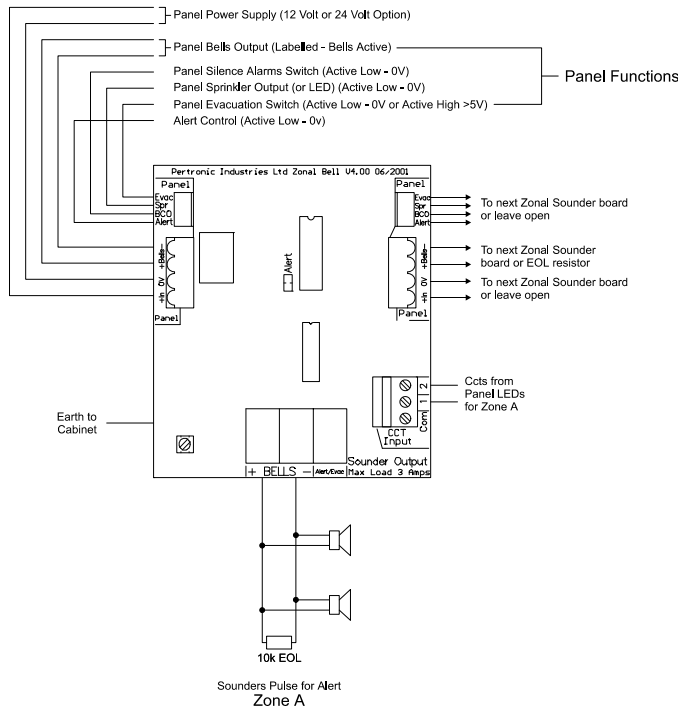

Connection Diagram : Quad Unit

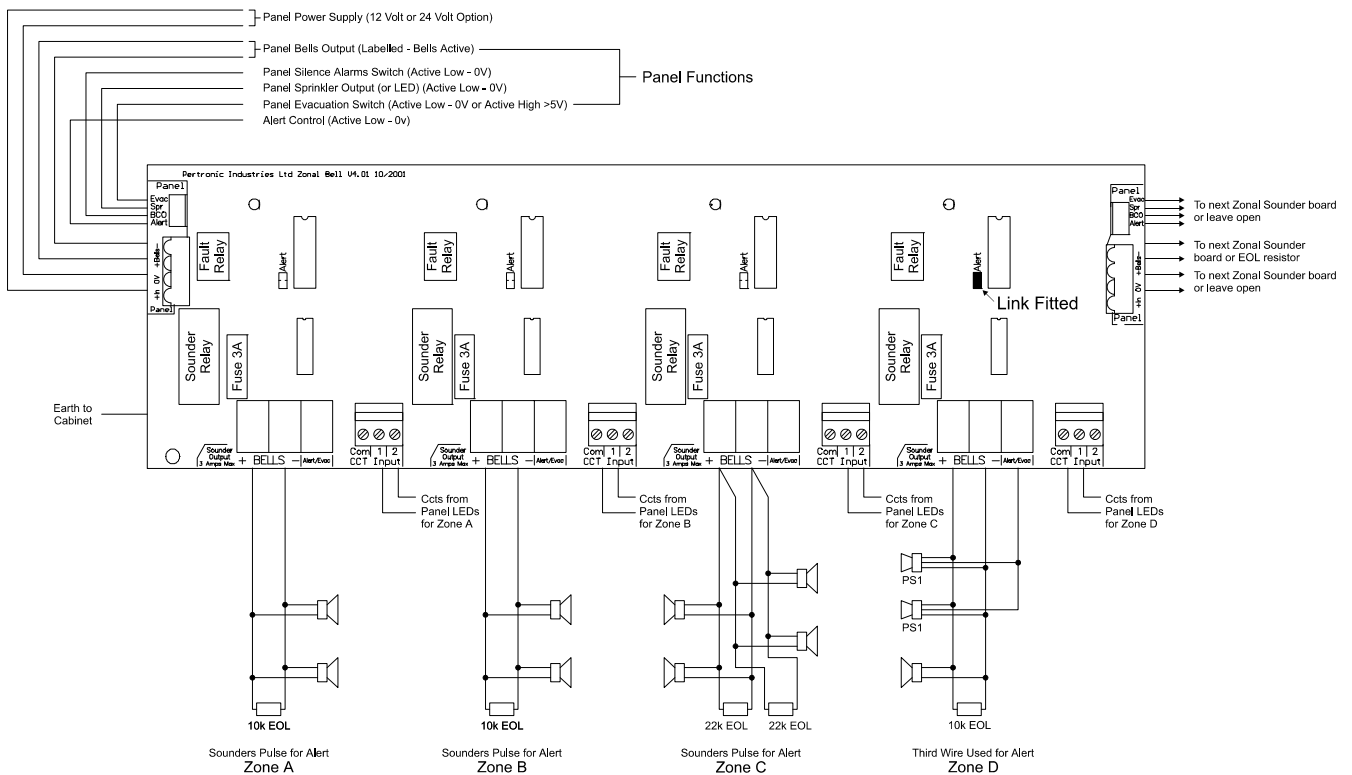

Product Codes:

Description	Code
Zonal Bell Monitor Board : 1-Way : 12Vdc	F16ZBB
Zonal Bell Monitor Board : 1-Way : 24Vdc	ZMB24V
Zonal Bell Monitor Board: 4-Way : 12Vdc	F16ZBB4WAY
Zonal Bell Monitor Board: 4-Way : 24Vdc	ZMB24V4WAY

PERTRONIC INDUSTRIES LTD

Head Office:
 17 Eastern Hutt Rd, Wingate, Lower Hutt
 Tel (04) 567-3229 Fax (04) 567-3644

www.pertronic.co.nz
 sales@pertronic.co.nz
 tech@pertronic.co.nz

Auckland Office:
 119 Lansford Cres, Avondale, Auckland
 Tel (09) 820-8228 Fax (09) 820-8284

'Pertronic' and 'Firetronix' are registered trademarks of Pertronic Industries Ltd