

CONVENTIONAL

Rate of Rise Temperature Detector
Model 5451EIS



Product Overview

Features

- Sleek low profile design
- Low current draw
- Remote LED option
- Simple plug-in installation
- Compatible with standard B401 mounting base
- Built-in test switch
- Tamper-resistant
- Suitable for use in up to Zone 0
- Approved for use with Zener safety barriers or galvanic isolators
- BASEEFA approval to EEX ia IIB T5
- Complies with EN54 - 5:2000 (Amendment 1) Class A1R



Description

Model 5451EIS is an intrinsically safe rate of rise detector with fixed temperature alarm. It uses state-of-the-art dual thermistor technology to provide maximum sensitivity. This detector is designed to afford open area protection and is for use in hazardous areas where potentially explosive atmospheres are likely to arise (confirm classification of equipment required with your responsible authority). Model 5451EIS detectors are designed to be used with compatible panels only.

Each detector has two LEDs to provide a local visual indication of detector status. Once the detector senses a fire, it latches in alarm and remains in this condition until it is reset by a momentary power interruption.

Model 5451EIS rate of rise detectors include a tamper feature that prevents removal from their mounting base (if enabled) without the use of a tool. In addition, these detectors can be easily tested by activating an internal reed switch with a test magnet.

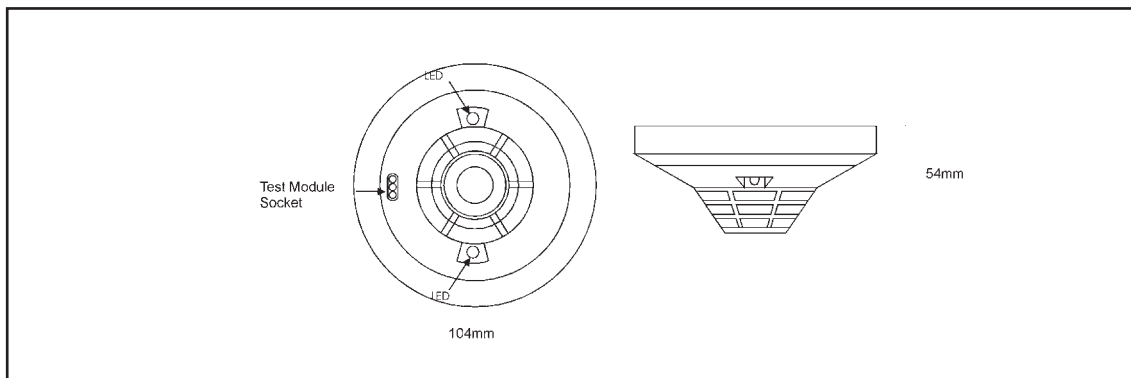

Architect/Engineer Specifications

5451EIS Intrinsically Safe Rate of Rise Temperature Detector

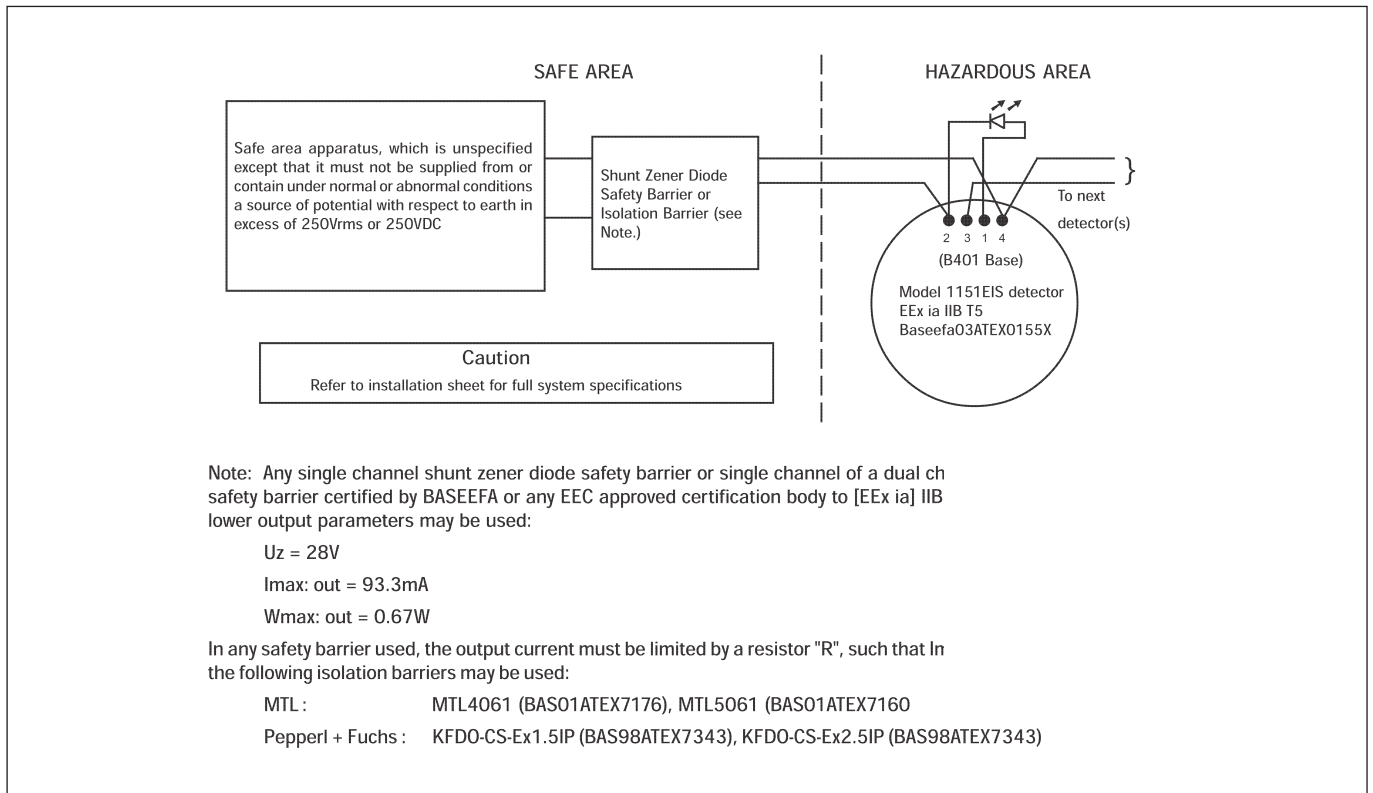

Electrical Specifications

Operating Voltage Range

15 to 32VDC Latching alarm reset by momentary power interruption

Typical Standby Current (maximum)

100µA at 24VDC

Environmental Specifications

Operating Temperature Range

-10°C to 55°C

Humidity

10% to 93% Relative Humidity (non-condensing)

Intrinsic Safety Rating

EEx ia IIB T5

Mechanical Information

Height

54mm

Diameter

104mm

Weight

80g (excluding base)

Max Wire Gauge for Terminals

2.5mm²

Colour

Pantone Warm Grey 1C

Material

Bayblend FR110

Product Range

Compatible Bases

B401, B401DG

System Sensor Europe (Technical Services)

Charles Avenue
 Burgess Hill
 RH15 9TQ
 United Kingdom
 Tel: +44 (0)1444 238820
 Fax: +44 (0)1444 248123
 sse.technical@systemsensoreurope.com
 www.systemsensoreurope.com

Copyright © 2005 System Sensor. All rights reserved. All technical data is correct at time of publication and is subject to change without notice. All trademarks acknowledged. Installation information: in order to ensure full functionality, refer to the installation instructions as supplied.