

# 4-Wire Duct Smoke Detector

## Model

DH100ACDCI 4-Wire Ionization  
Duct Smoke Detector

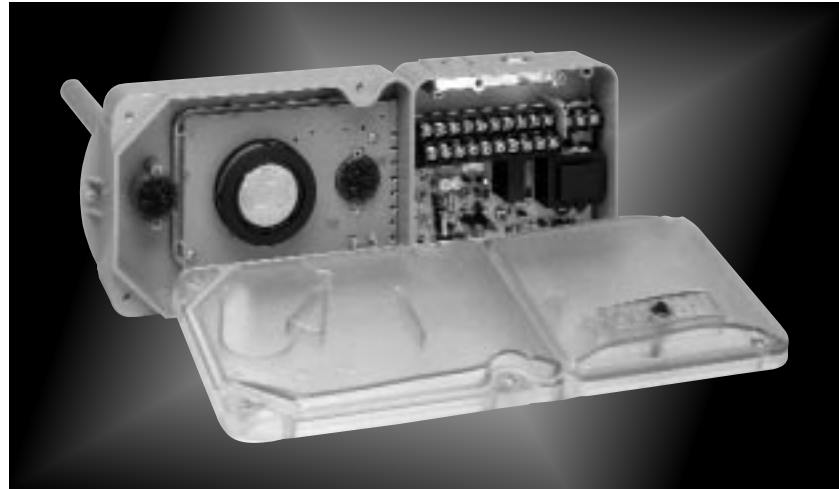

## Product Overview

**Air velocity rating from  
500 to 4000 feet per minute  
(2.54 to 20.32 m/sec.)**

**Patented interconnectability for multi-  
fan shutdown (up to ten air handlers)**

**Patented telescopic sampling tube**

**Patented cover tamper trouble signal**

**24 VAC/DC or 120/240 VAC operation**

**High-Low voltage barrier**

**Equipped with two DPDT Form C relay  
contacts**

**Built-in reset button**

**Outside mounting tabs**

**Easy and quick mounting to round  
or rectangular ducts from 1'-12'  
(0.3-3.7 meters) wide**

**Easy to clean**

**UL recognized field-replaceable  
power and sensor boards**

**Remote test station option**

**Remote sounder option**

**Transparent cover for convenient  
visual inspection**

**UL 268A listed**

**3-year warranty**

**Photoelectric model available**

The System Sensor Innovair™ DH100ACDCI is a 4-wire ionization air duct smoke detector capable of sensing smoke in air velocities from 500 to 4,000 feet per minute (2.54 to 20.32 m/sec). This detector was developed to constantly monitor the air within a duct and to detect the presence of smoke.

The two available form C relay contacts provide reliable performance for the management of fans, blowers and air conditioning systems. These HVAC devices can be configured to prevent the spread of toxic smoke and fire gasses through a protected area

The Innovair family is designed for simplified installation and easy maintenance. The modular construction allows for easy cleaning and uncomplicated field replacement of the UL recognized power and sensor boards. The patented cover missing feature insures the cover is securely tightened following routine cleaning and maintenance. The patented interconnectability feature allows multiple Innovairs to communicate with each other. In the event smoke is detected, the Innovair will signal the remaining interconnected detectors to initiate their relays for smoke control.

**WARNING:** Duct smoke detectors have specific limitations.

### **DUCT SMOKE DETECTORS ARE:**

NOT a substitute for an open area smoke detector,  
NOT a substitute for early warning detection, and  
NOT a replacement for a building's regular fire  
detection system.

Refer to NFPA 72 and 90A for additional information about the proper application of duct smoke detectors.

## Architectural/Engineering Specifications

The air duct smoke detector shall be a System Sensor Model DH100ACDCI Series Duct Smoke Detector. The detector housing shall be UL listed per UL 268A specifically for use in air handling systems. The detector shall operate at air velocities of 500 feet per minute to 4000 feet per minute (2.54 to 20.32 meters/second). The unit shall be capable of controlling up to ten (10) air handling systems when interconnected with other detectors. The detector shall be capable of providing a trouble signal in the event that the front cover is removed. It shall be capable of local testing via magnetic switch or remote testing using the SSK451 Multi-Signaling Accessory or the RTS451KEY Remote Test Station. The unit shall be reset by local reset button or remote test station. The duct smoke detector housing shall incorporate an airtight smoke chamber in compliance with UL 268A, Standard for Smoke Detectors for Duct Applications. The housing shall be capable of mounting to either rectangular or round ducts without adapter brackets. An integral filter system shall be included to reduce dust and residue effects on detector and housing, thereby reducing maintenance and servicing. Sampling tubes shall either be telescoping or be easily installed by passing through the duct housing after the housing is mounted to the duct. The unit shall provide a spacial separation of no less than 1/4" (6.4 mm) and/or a physical barrier between the high and low voltage terminals. The enclosure shall meet all applicable NEC and NFPA standards regarding electrical junction boxes. Terminal connections shall be of the strip and clamp method suitable for 12-18 AWG wiring.

## Wiring Guide

System wiring diagram for 4-wire duct smoke detectors

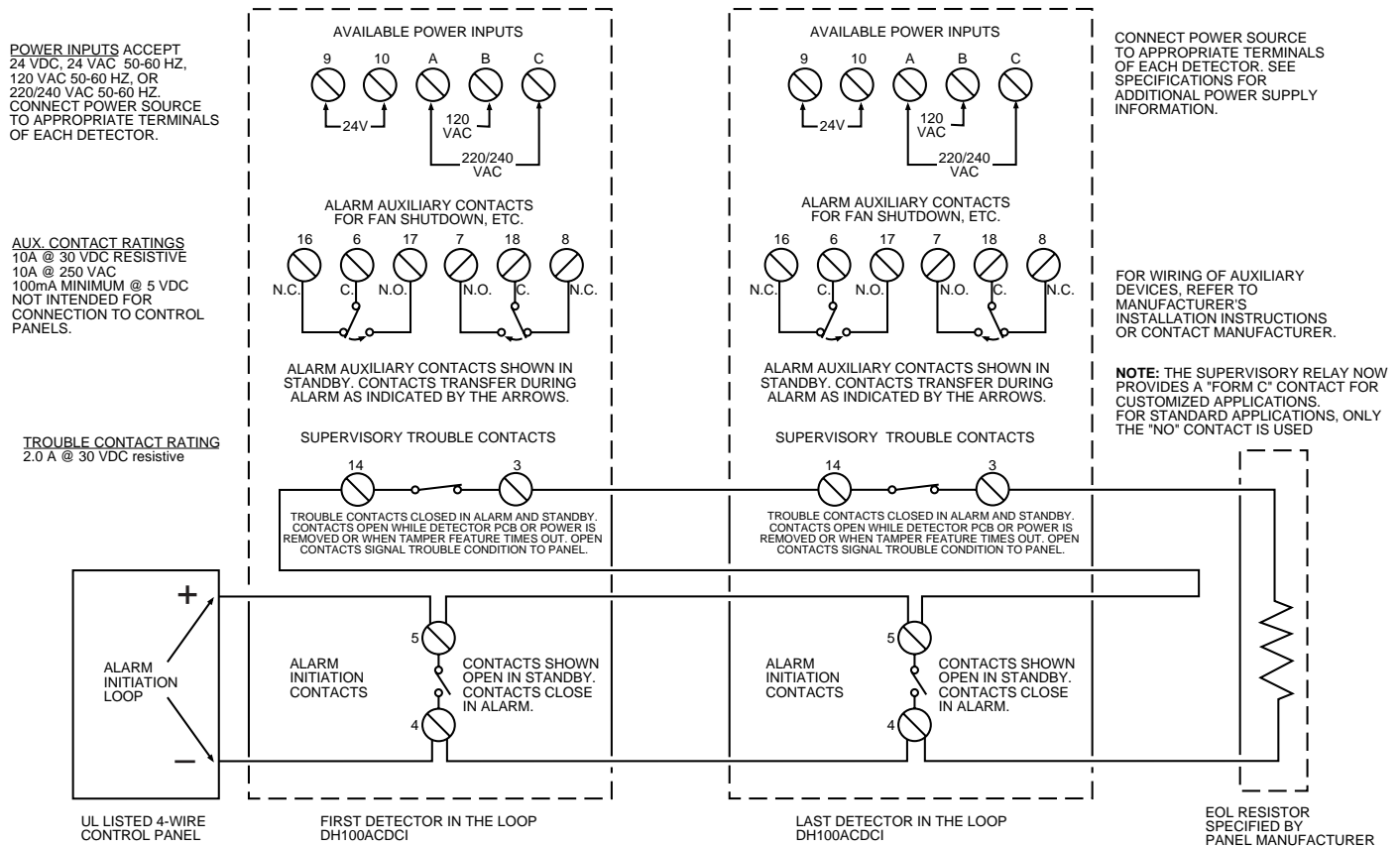

## Specifications

**Size**  
 14<sup>3</sup>/<sub>8</sub>" (37 cm.) Length  
 5<sup>1</sup>/<sub>2</sub>" (14 cm.) Width  
 2<sup>3</sup>/<sub>4</sub>" (7 cm.) Depth

**Shipping Weight**  
 3<sup>3</sup>/<sub>4</sub> lbs. (1.7 kg.)

**Operating Temperature Range**  
 32° to 120° F (0° to 49° C)

**Operating Humidity Range**  
 10% to 93% relative humidity non-condensing

**Air Duct Velocity**  
 500 to 4000 ft./min. (2.54 to 20.32 m/sec.)

A78-2352-12

## Electrical Ratings – DH100ACDCI (Includes Detector)

Power supply voltage:	20-29 VDC	24 VAC 50-60-Hz	120 VAC 50-60 Hz	220/240 VAC 50-60 Hz
Input capacitance:	270 $\mu$ F max.	270 $\mu$ F max.	N/A	N/A
Reset voltage:	3.0 VDC min.	2.0 VAC min.	10 VAC min.	20 VAC min.
Reset time (with RTS451):	.03 to 0.3 sec.	.03 to 0.3 sec.	.03 to 0.3 sec.	.03 to 0.3 sec.
Reset time (by power down):	0.6 sec. max.	0.6 sec. max.	0.6 sec. max.	0.6 sec. max.
Power up time:	34 sec. max.	34 sec. max.	34 sec. max.	34 sec. max.
Alarm response time:	2 to 17 sec.	2 to 17 sec.	2 to 17 sec.	2 to 17 sec.
Sensitivity Test:	See detector label	See detector label	See detector label	See detector label

Power Supply Voltage	20 - 29 VDC	24 VAC 50 - 60 Hz	120 VAC 50 - 60 Hz	220/240 VAC 50 - 60 Hz
----------------------	-------------	-------------------	--------------------	------------------------

### CURRENT REQUIREMENTS (USING NO ACCESSORIES)

Max. standby current	15 mA	35 mA RMS	25 mA RMS*	15 mA RMS*
Max. alarm current	70 mA	125 mA RMS	35 mA RMS*	25 mA RMS*

### CONTACT RATINGS

Alarm initiation contacts (SPST)	2.0A @ 30 VAC/DC (0.6 power factor)
Alarm auxiliary contacts (DPDT)	10A @ 30 VDC 10A @ 250 VAC
Note: Alarm auxiliary contacts must switch 100mA minimum at 5VDC. Alarm auxiliary contacts shall not be connected to initiating circuits of control panels. Use the alarm initiation contact for this purpose.	
Trouble contacts (SPDT)	2.0A @ 30 VDC (resistive)

ACCESSORY CURRENT LOADS AT 24 VDC			
DEVICE	STANDBY	TROUBLE	ALARM
APA451	12.5mA Max.	n/a	30mA Max.
PA400	0mA	n/a	15mA Max.
RA400Z	0mA	n/a	10mA Max.
RTS451/RTS451KEY	12mA*	n/a	7.5mA Max.
SSK451	5mA Max.	9mA Max.	30mA Max.

\*NOTE: When a unit is powered at the 120VAC or 220/240VAC input, any combination of accessories may be used such that the given accessory loads are: 60 mA or less in the standby state; 110 mA or less in the alarm state.

### Wiring diagram for DH100ACDCI to APA451

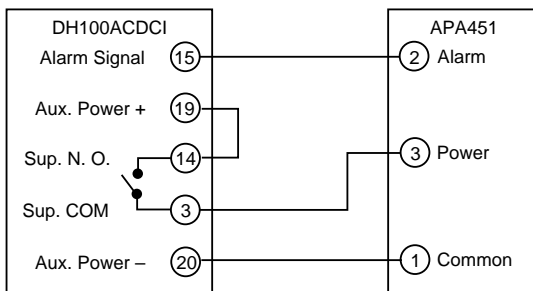

NOTE: Wiring diagram shown is for DH100ACDCI 4-wire duct smoke detector system equipped without a control panel.

NOTE: A trouble condition is indicated when the green LED is not illuminated.

### Wiring diagram for DH100ACDCI to SSK451 and interconnect feature

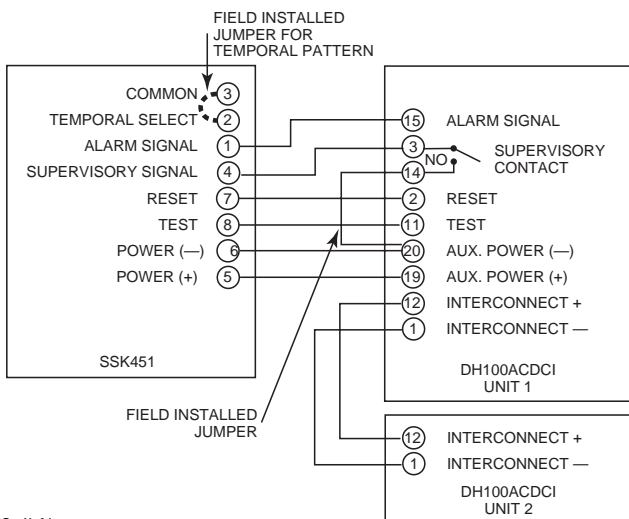

#### Coil Note:

Please note that the magnetic coil supplied with the RTS451/RTS451KEY is not required when these accessories are used with the DH100 detectors. The functionality of the magnetic coil has been designed into the circuitry of the Innovair duct smoke detectors.

### Important Interconnect Notes

- When using the interconnect feature, all interconnected units must be powered with the same, independent supply.
- Polarity must be maintained throughout the interconnect wiring. Connect terminal 12 on unit 1 to terminal 12 on unit 2 and so on. Similarly, connect terminal 1 on unit 1 to terminal 1 on unit 2 and so on.

### Wiring diagram for the RTS451/RTS451KEY and interconnect feature

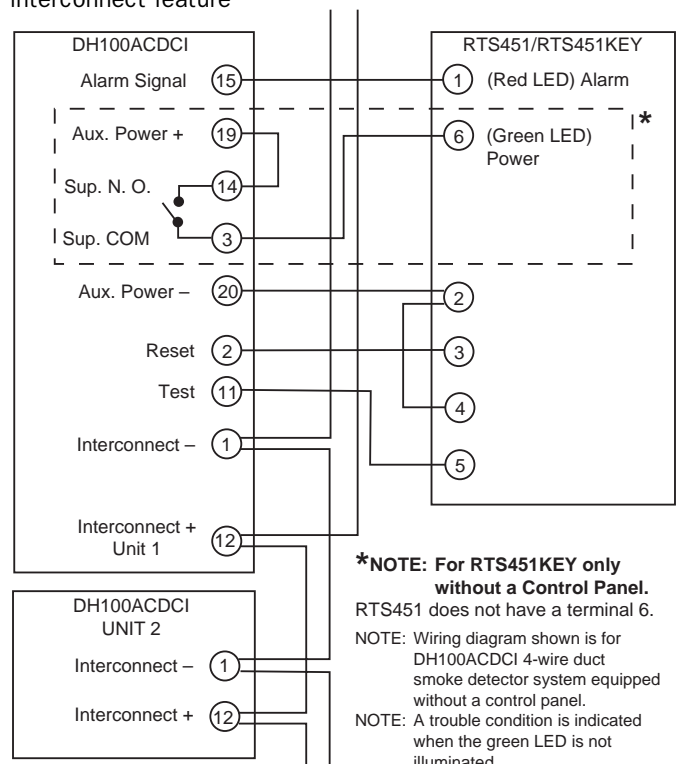

**\*NOTE: For RTS451KEY only without a Control Panel.** RTS451 does not have a terminal 6.  
NOTE: Wiring diagram shown is for DH100ACDCI 4-wire duct smoke detector system equipped without a control panel.  
NOTE: A trouble condition is indicated when the green LED is not illuminated.

## Ordering Information

Part No.	Description
DH100ACDCI	4-wire ionization duct detector
A5052	Replacement ionization detector board
A5064	Replacement 4-wire power board

### Accessories

ST-1.5	Metal sampling tube duct widths 1'-2' (0.3-0.6 m)	MOD400R	Sensitivity test module
ST-3	Metal sampling tube duct widths 2'-4' (0.6-1.2 m)	RA400Z	Remote annunciator alarm LED
ST-5	Metal sampling tube duct widths 4'-8' (1.2-2.4 m)	F36-09-11	Replacement air filters (two per package)
ST-10	Metal sampling tube duct widths 8'-12' (2.4-3.7 m)	M02-04-00	Test magnet
T80-71-00	Replacement telescoping sampling tube	P48-21-00	End cap for metal sampling tubes
P48-55-00	Replacement end cap for T80-71-00	S08-39-01	Photo replacement screen
SSK451	Multi-Signaling accessory	PA400W	Mini-Alert sounder
RTS451KEY	Remote test station with key lock	PS24LOW	Mini-Alert add-on strobe
RTS451	Remote test station	PS12/24LENSW	Wall-mount "SMOKE" lens
APA451	Remote annunciator with piezo alarm		

## Accessories

System Sensor provides system flexibility with a variety of accessories, including two remote test stations, and several different means of visible and audible system annunciation. As with our duct detectors, all duct smoke detector accessories are UL listed.

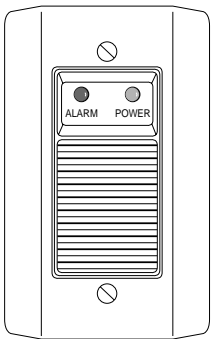

**APA451**  
Piezo Annunciator  
(UL S4011)

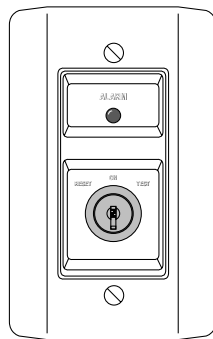

**RTS451KEY**  
Remote Test Station  
with Key (UL S2522)

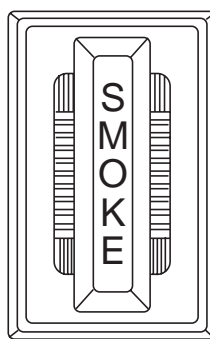

**PA400W**  
Mini-Alert Sounder  
(UL S3593)  
shown with PS24LOW add-on strobe (PS12/24SLENSW smoke lens option available)

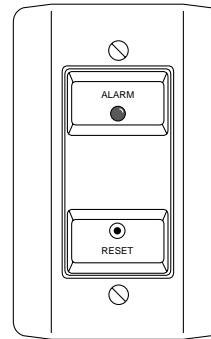

**RTS451**  
Remote Test Station  
(UL S2522)

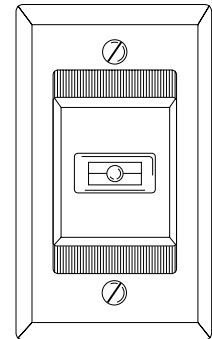

**RA400Z**  
Remote Annunciator  
(UL S2522)

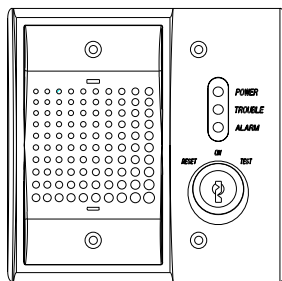

**SSK451**  
Multi-Signaling  
Accessory  
(UL 268A)

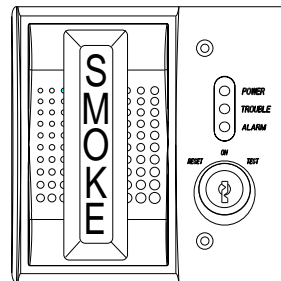

**SSK451**  
Multi-Signaling Accessory  
(UL 268A)  
shown with PS24LOW add-on strobe (PS12/24SLENSW smoke lens option available)

## System Sensor Sales and Service

**System Sensor Headquarters**  
3825 Ohio Avenue  
St. Charles, IL 60174  
Ph: 800/SENSOR2  
Fx: 630/377-6495  
Documents-on-Demand  
800/736-7672 x3  
www.systemsensor.com

**System Sensor Canada**  
Ph: 905.812.0767  
Fx: 905.812.0771

**System Sensor Europe**  
Ph: 44.1403.276500  
Fx: 44.1403.276501

**System Sensor in China**  
Ph: 86.29.524.6253  
Fx: 86.29.524.6259

**System Sensor in Singapore**  
Ph: 65.273.2230  
Fx: 65.273.2610

**System Sensor – Far East**  
Ph: 85.22.191.9003  
Fx: 85.22.736.6580

**System Sensor – Australia**  
Ph: 613.54.281.142  
Fx: 613.54.281.172

**System Sensor – India**  
Ph: 91.124.637.1770 x.2700  
Fx: 91.124.637.3118