

20W 12Vdc 100Vrms Line Amplifier (EVAC20W12V)

Head Office

Wellington

PO Box 35-063
Naenae, 5011
Lower Hutt
17 Eastern Hutt Rd
Wingate
Lower Hutt 5019
Tel (04) 567-3229

www.pertronic.co.nz

sales@pertronic.co.nz
tech@pertronic.co.nz

Auckland Office

PO Box 15-867
New Lynn
Auckland 0640
359 Onehunga Mall
Onehunga
Auckland 1061
Tel (09) 633-0226

Product Overview:

The Pertronic 20W Amplifier (**EVAC20W12V**) is an evacuation amplifier with integral evacuation tone and message generator, together with a fault detection system. It is designed for use in emergency warning systems with supervised 100 Volt Line distribution systems. The amplifier delivers up to 20 Watts of audio power to the 100 Volt line.

The **EVAC20W12V** generates an evacuation tone with a voice message as specified in NZS 4512:2010.

The amplifier is controlled by the BELL output of a fire alarm panel such as the **Pertronic F1** or **F4**.

When in standby, the 100 Volt line is connected to the BELL circuit. This allows the fire alarm panel to detect short or open circuit faults on the 100 Volt line. The BELL circuit drives a small dc current through the 100 Volt line, which must be terminated with a suitable end of line resistor. It is important to note that every speaker connected to the supervised 100 Volt Line must be specially designed for emergency warning systems, with each speaker incorporating a DC blocking capacitor.

Features:

- ▶ Generates the 'Evacuation' tone with verbal messages as specified by NZS 4512:2010
- ▶ Can be directly mounted into the Pertronic F1 or F4 Conventional Fire Alarm panels, but can be used with any 12 V Fire Alarm system
- ▶ Activated when the BELL circuit voltage polarity reverses to the 'Alarm' state
- ▶ In the 'Normal' state, the amplifier draws practically no current (less than 0.2 μ A) and appears transparent to the Fire Alarm panel
- ▶ The 100 Vrms line is internally connected to, and monitored by the panel's BELL circuit
- ▶ The amplifier's 100 Vrms line is short-circuit protected and is capable of driving up to 20 W (13.7 Vdc supply) into connected PA loud speakers, eg. Pertronic PSS1 and PSSB401



**Pertronic 20W, 12V Amplifier
EVAC20W12V**

Specifications:

Electrical:	Operating Voltage 9.6 to 14.4 Vdc Reference 13.7 Vdc	Quiescent Current 0.2 μ A @ 12 Vdc	Alarm Current 2.0 A @ 13.7 Vdc - with 20 Wrms load
Power Output	20 W @ 100 Vrms line : 13.7 Vdc Supply 15 W @ 100 Vrms line : 10.5 Vdc Supply		
Environmental:	Operating Temperature Range 0 to 30 °C	Humidity 10 to 95 % RH (non-condensing)	
Mechanical:	Dimensions 100 x 70 x 47 (L x W x D mm)		Weight 300 g

- ▶ Monitoring: Monitored for open and short-circuit (10 k Ω , 2 W, EOL resistor)
- ▶ Tone: Evacuation tone and verbal message, compliant to NZS 4512:2010

NZS 4512:2010 Tone Characteristics:

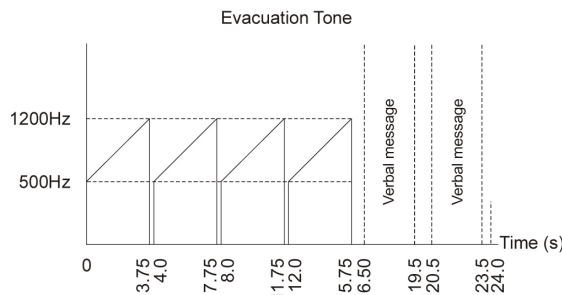

Product Code	Description
EVAC20W12V	EVAC Amplifier, 20W 12V, SMD version
PSS1-R	Pert Sounder Speaker 1W Flush - Red
PSS1-W	Pert Sounder Speaker 1W Flush - White
PSSB401	Pertronic Speaker with B401 Base

Operation:

The Amplifier is connected to the fire alarm panel sounder circuit output. The BELL terminals '+' and '-' are connected to the corresponding '+' and '-' terminals on the amplifier.

In the 'Normal' state, the panel monitors the 100 V line EOL (10 k Ω , 2 W) resistor by applying an inverted voltage to the amplifier input terminals. In this state the amplifier connects the EOL resistor to the panel BELL output. A 10 k Ω , 2 W EOL resistor must be used across the 100 Vrms line for correct operation of the amplifier monitoring circuit.

In the 'Alarm' state, the fire alarm panel reverses the sounder voltage causing the amplifier to activate and output a repeating 'Evacuation Tone followed by a voiced Evacuation Message' onto the 100 Vrms loudspeaker circuit. The amplifier is NOT monitored during the 'Alarm' state.

If the amplifier output is overloaded, or the supply voltage becomes 'Off-Normal', the amplifier will signal a defect by turning the Defect LED ON (refer to Table 1)

Defect LED	ON LED	Defect Description
Off	Off	Amplifier inactive
Off	Steady	Amplifier active
1 st flash is long	Off	Supply voltage is out of range
2 nd flash is long	Off	Input current is too high
3 rd flash is long	Off	Output voltage too low, short detected

Table 1: LED Decoding

The 100 Vrms Line may have a maximum of three spurs. For these configurations an EOL resistor of the appropriate value must be installed at the end of each spur (refer to Table 2).

Number of Spurs	EOL Resistor Value for Each Spur
1	1 x 10 k Ω , 2 W
2	1 x 22 k Ω , 1 W on each spur
3	1 x 33 k Ω , 1 W on each spur

Table 2: Spurs

Capacitively-coupled 100 Vrms PA speakers must be used with the 20W amplifier. The capacitor must be bipolar and able to withstand 250 V peak line voltage. The value should be approximately 1 μ F per watt of power for each speaker.

The 100 Vrms speaker wiring must be separated from other wiring to prevent interference from cross-talk.

Loading of the 100 Vrms line must not exceed 20W.

An excessive load will cause the amplifier to current limit and shutdown. The symptoms for this may be interruptions in the audio output and two or more amplifiers broadcasting out of synchronization.

Loading of the Bell output must not exceed the maximum fuse or relay ratings.

F1 Panel Bell Circuit: Fuse 1 = 3 A

F4 Panel Bell Circuit: Fuse 1 = 5 A

12 V, 20 W Amplifier Line Relay maximum contact current = 3 A

Connection Diagram:

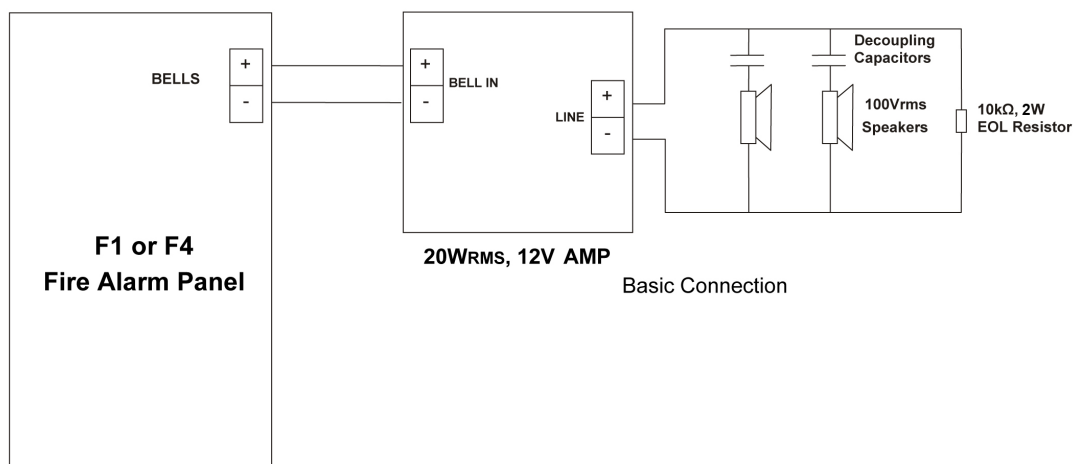

PERTRONIC INDUSTRIES LTD

Head Office:

17 Eastern Hutt Rd, Wingate, Lower Hutt 5019
Telephone (04) 567-3229

www.pertronic.co.nz

sales@pertronic.co.nz

tech@pertronic.co.nz

Auckland Office:

59 Onehunga Mall, Onehunga, Auckland 1061
Telephone (09) 633-0226