

PERTRONIC INDUSTRIES LTD

EVAC20W24V and EVAC20W24V-T3

AMPLIFIER INSTALLATION NOTE



Overview:

The 20W 24V Amplifier is one of a range of Amplifiers manufactured by Pertronic Industries.

The 20W 24V Amplifier generates the Evacuate tone and verbal message as per NZS 4512:2010, AS 2220 or ISO 8201 (T3)—dependent on firmware version installed.

The 20W 24V Amplifier has a monitored 100 Vrms output that can provide up to 20 W of power (27.4 V supply) to connected PA loud speakers. The output is short-circuit protected.

The 20W 24V Amplifier is designed for connection to the monitored sounder output of an F16e, F100, or F120 Fire Alarm Panel; it is activated when the sounder circuit voltage polarity is changed to the alarm state.

In the 'Normal' state, the amplifier 100 Vrms line is internally connected to the panel sounder circuit. The amplifier draws virtually no current (less than 0.2 μ A) and appears transparent to the panel. If there is a wiring fault on the 100 Vrms line or between the amplifier and the panel bell circuit, the Fire Alarm Panel goes into fault.

Specifications:

Targeted Panel:	F16e, F100, and F120 Fire Alarm Panels	
Board Dimensions:	106 x 77 x 38 mm	L x W x D
Mounting Dimensions:	93 x 69 mm	L x W
Operating Voltage:	19.2 to 28.8 Vdc	
Operating Current:	1.2 A @ 27.4 Vdc with 20 Wrms load	
Power Output:	27.4 Vdc Supply: 20 W @ 100 Vrms line	
Tone:	Evacuation tone and verbal message, compliant to AS 2220 or ISO 8201 (T3) See Fig 1	
Monitoring (by panel):	10 k Ω 2 W EOL resistor supplied	

(Fig 1) AS2220 and T3 Tone Characteristics:

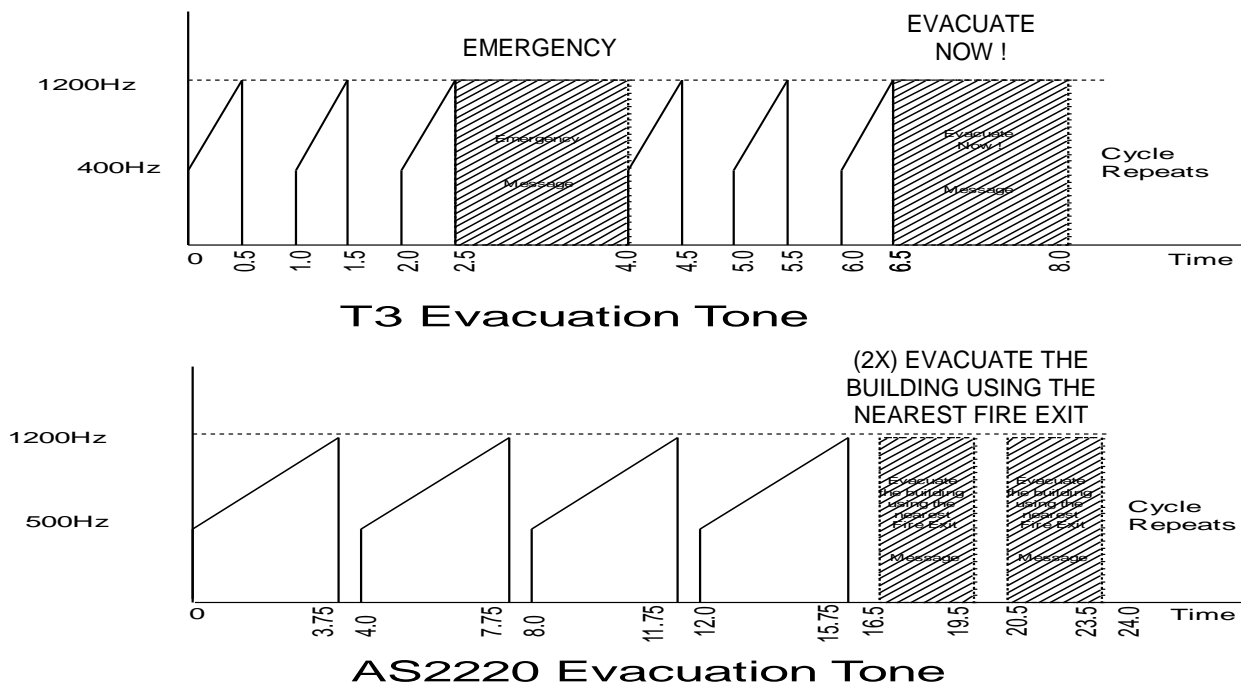

PERTRONIC INDUSTRIES LTD

EVAC20W24V and EVAC20W24V-T3

AMPLIFIER INSTALLATION NOTE



Operation:

The Amplifier is connected to the panel sounder circuit output as shown in the connection diagrams. Sounder terminals '+' and '-' are connected to the corresponding '+' and '-' terminals on the amplifier.

In the 'Normal' state, the Panel monitors the 100 V line 10 k Ω 2 W EOL resistor by applying a reversed voltage to the amplifier input terminals. In this state, the amplifier connects the 10 k Ω 2 W EOL line resistor to the Warning System output. A 10 k Ω 2 W resistor must be used across the 100 Vrms line for correct operation of the amplifier's monitoring circuit.

In the 'Alarm' state, the panel reverses the bell voltage, causing the amplifier to activate and to put a 100 Vrms evacuation tone and voice message on the loudspeaker circuit. During the Alarm state, monitoring of the amplifier ceases.

If the amplifier's output is overloaded or if the supply voltage becomes off-normal, the amplifier will signal a defect by flashing the Defect LED, in a sequences of 3 flashes; see Table 1.

Table 1. LED Decoding

Defect LED	ON LED	Defect Description
Off	Off	Amplifier inactive
Off	Steady	Amplifier active
1 st flash is long	Off	Supply Voltage is out of range
2 nd flash is long	Off	Input current is too high
3 rd flash is long	Off	Output voltage too low, short detected

The 100 Vrms Line may be spurred provided the total number of system spurs does not exceed three. In these configurations, the EOL resistor value must be changed to provide the correct monitoring to the panel (See table 2).

Table 2. Spurring

NUMBER OF SPURS	EOL RESISTOR VALUE FOR EACH SPUR
1	1 x 10 k Ω 2W
2	1 x 22 k Ω 1W on each spur
3	1 x 33 k Ω 1W on each spur

Capacitively-coupled 100 Vrms PA Speakers must be used with the 20 W Amplifier. The capacitor must be bipolar and able to withstand 200V peak line voltage. The value should be around 1 μ F per watt of power for each speaker.

A common problem of 100 Vrms PA installations is the coupling of unwanted noise into the 100V line. Although the 20 W Amplifier has been designed to reduce the effects of coupled noise, it is recommended practice that all 100V line wiring be separated from all other wiring by at least 1 meter. This includes mains wiring, ELV wiring, loop wiring, and telephone wiring.

Loading of the 100 Vrms line must not exceed 20W. Maximum cable capacitance must remain below 80 nF (when supply is less than 28V). Excessive load or cable capacitance may cause the amplifier to current-limit and shut down.

It is recommended that suitable Cable be used when installing 100 Vrms Speaker lines.

See Table 3 for the cable specification.

Table 3. Evac Cable

Resistance	0.032 ohms/m(return)
Capacitance	80 pF/m
Maximum cable run	750 m

PERTRONIC INDUSTRIES LTD

EVAC20W24V and EVAC20W24V-T3

AMPLIFIER INSTALLATION NOTE



Voice Messages:

Evacuation tone for the EVAC20W24V: "Evacuate the building using the nearest fire exit."
 Evacuation tone for the EVAC20W24V-T3: "Emergency," followed by: "Evacuate now."

Connection Diagrams:

Basic Connection Diagram

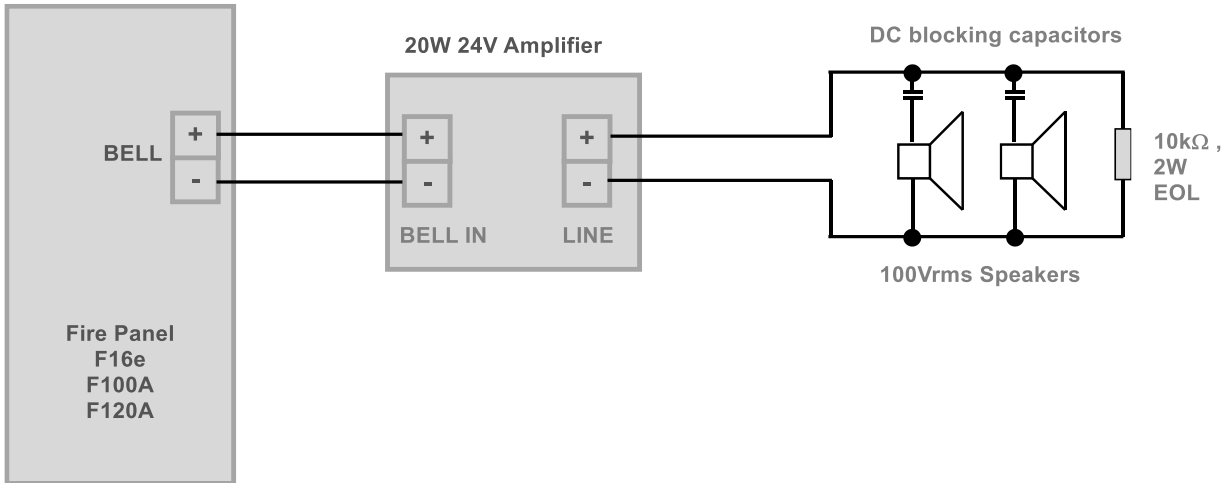

Spurred Speaker Wiring Connection

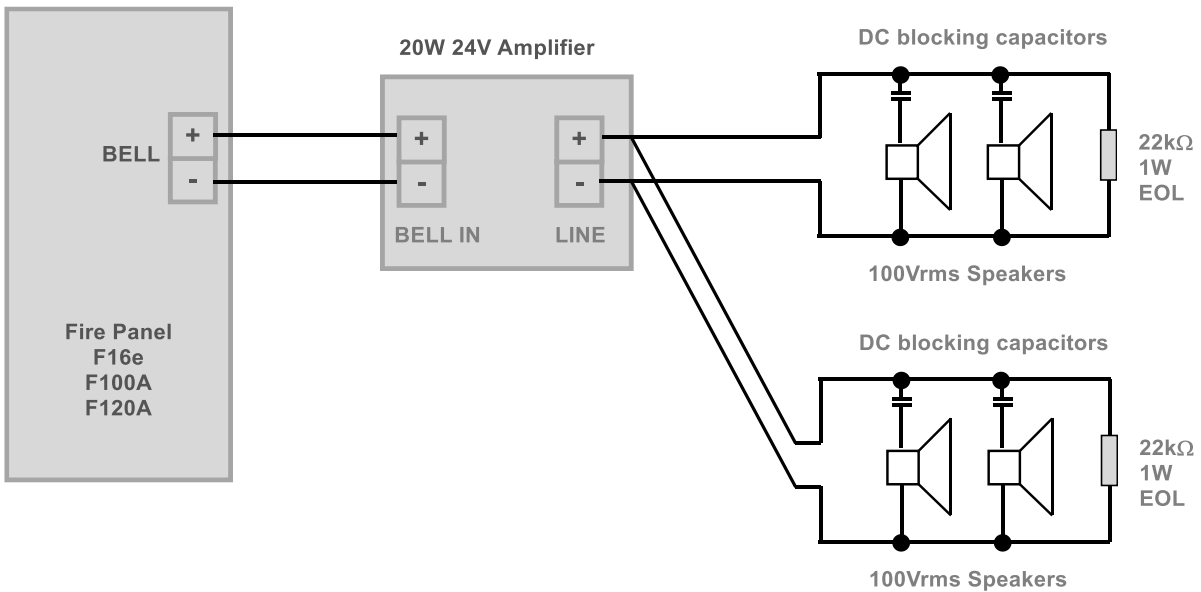

PERTRONIC INDUSTRIES LTD

EVAC20W24V and EVAC20W24V-T3

AMPLIFIER INSTALLATION NOTE



Circuit Board Layout

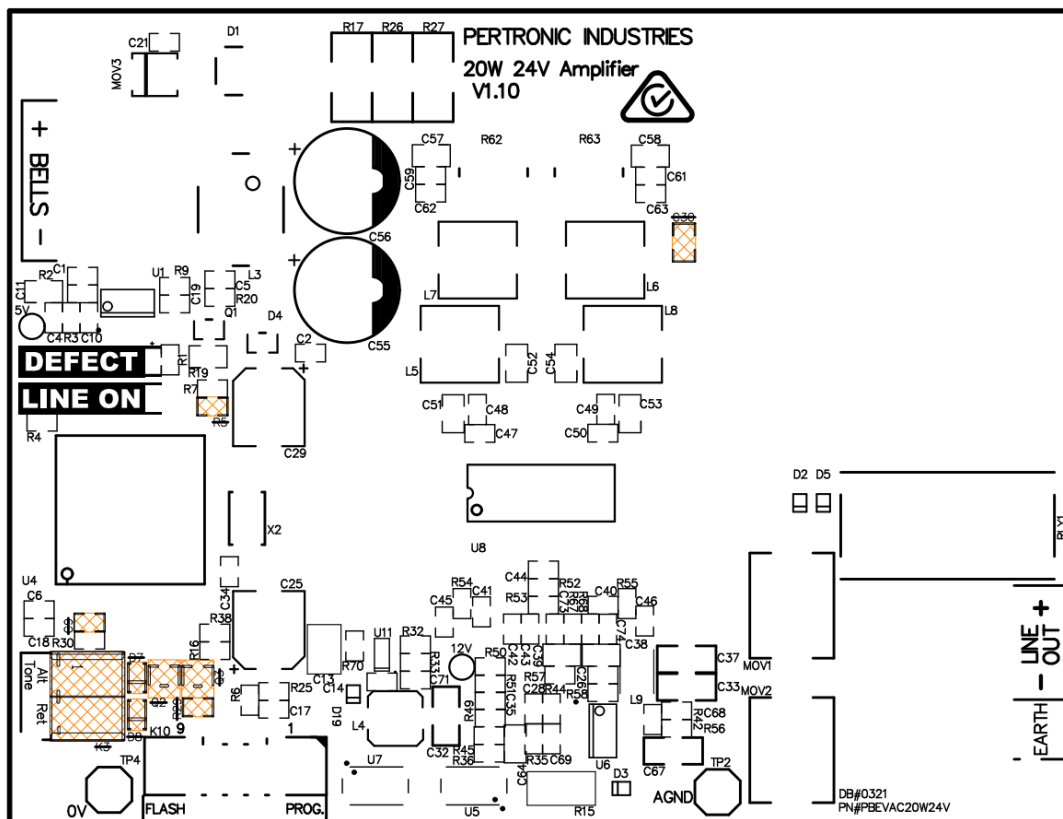

Product Code	Description
EVAC20W24V	20W 24V Amplifier with AS2220 Evacuation tone, SMD version
EVAC20W24V-T3	20W 24V Amplifier with T3 tone, SMD version