

PERTRONIC INDUSTRIES LTD

Audio Distribution Module, 4-Way (ADM-4)



Installation Note

Overview:

The **Pertronic Audio Distribution Module 4-Way (ADM-4)** provides multiple independently controlled and monitored 100 Vrms audio lines (channels). Several **ADM-4** modules may be connected to a single amplifier, providing **four switchable audio channels** per **ADM-4**. This simplifies audio system installations by allowing four or more spurs from a single 100 Volt audio line without compromising the defect monitoring system.

A system built with ADM-4 modules will continue operating even if some channels develop faults. If any channel becomes short-circuited, output on all channels will be interrupted. After a brief delay (about 20 seconds), the shorted channel will be disconnected. Output will then resume on the unaffected channels. The monitoring system will continue to monitor the shorted channel, and it will automatically reconnect the channel if the fault is cleared.

The built-in fault monitoring system continually monitors the 100V output lines for open-circuit or short-circuit conditions, irrespective of whether the system is broadcasting an evacuation message, broadcasting non-urgent audio such as background music, or idling with no signal.

Each channel may be permanently enabled using the local DIP switch, or enabled/disabled by a remote control signal.

The module also includes a Type-C clean contact fault relay for connection to monitoring equipment. Optionally the module can signal a fault condition by switching a 6.8 k Ω fault resistance across the incoming audio lines. If required, the **Audio Distribution Module** can be configured to ignore faults in the active state, allowing for further downstream switching (for example, using the System Sensor M500S).

Features:

- » Simplifies installation of audio evacuation systems by providing multiple monitored audio channels
- » Multiple units can be connected together, providing four channels per unit
- » A short circuit on one channel will be isolated allowing audio transmission over the other channels
- » **Channel Select** input provides individual channel switching
- » Superior 80 Watt per channel switching capacity
- » On-board DIP switch allows individual channels to be permanently selected
- » Separate open-circuit (O/C) and short-circuit (S/C) fault indicators for each channel
- » Control inputs can be isolated from the on-board circuitry
- » User selectable End of Line input resistor to suit amplifier specifications
- » Compatible with Pertronic 20 Watt & 50 Watt amplifiers, and amplifiers controlled by the Pertronic EVAC Generator Module

Specification:

- | | | |
|--------------------------|---|--------------|
| » Dimensions | 140 x 98 x 27 | L x W x D mm |
| » Operating Voltage | 18 – 30 Vdc | |
| » Quiescent Current | 16 mA @ 27.4 Vdc | |
| » Maximum Fault Current | 25 mA @ 27.4 Vdc | |
| » Power per Channel | 80 W (100 Vrms Line) | |
| » Maximum Power Capacity | 250 W total per module | |
| » Monitoring (Output) | Monitored for open-circuit (O/C) and short-circuit (S/C) conditions | |
| » End of Line | 47 k Ω , 0.5 W EOL | |

- » Relay Rating (Fault Output) 2 A @ 30 Vdc Type-C clean contact
- » Recovery Time 20 seconds (approx.) After detecting short-circuit on any channel

100V Line

- » Maximum Voltage 100 Vrms
- » Fault Condition 6.8 kΩ placed across line (If jumper selected)

Control Inputs

- » External Drive Voltage 5 V to 30 Vdc
- » Current Per Input 5 mA to 8 mA

Installation:

1. Power Supply

The Audio Distribution Module 4-Way connects to the power supply via the 'DC SUPPLY IN' connector located at the top right of the board. The "DC SUPPLY OUT" connector may be used to supply power to additional devices. The DC supply must be connected at all times to enable the Audio Distribution Module to monitor the 100 V line channel outputs.

A green 'DC ON' indicator is always ON when power is available.



2. Control Inputs

The four output channels can be activated independently using the Channel Select inputs or can be permanently turned ON by selecting the corresponding DIP switch.

2.1 DIP Switch Always ON settings

Turn on the required channels permanently by selecting the appropriate DIP switch.

If the ALL switch is selected then switches 1-4 are overridden.

The example shown has Channels 2 and 4 Always ON and Channels 1 and 3 input controlled.

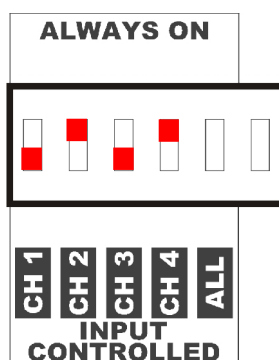

2.2 Activating Control Inputs

The Audio Distribution Module 4-Way has 6 constant-current inputs that can operate at the local potential or from a floating / isolated DC supply.

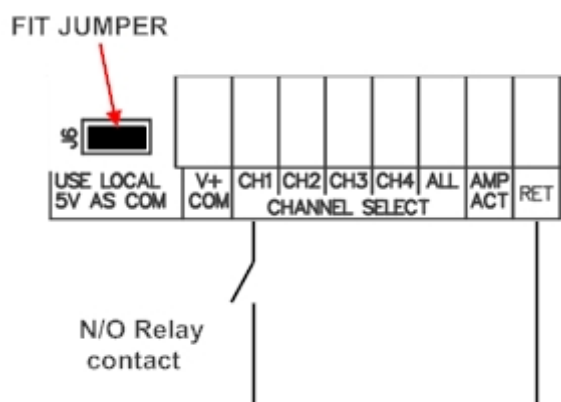

Figure 1: Relay Contact

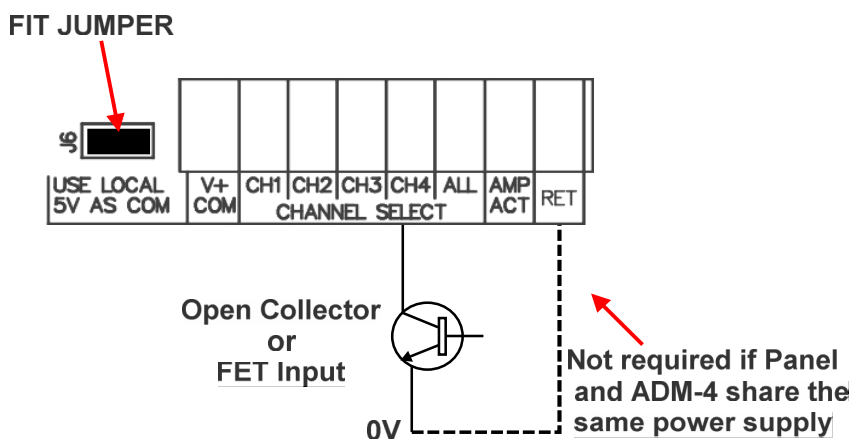

Figure 2: Open Collector or Open Drain
Using Local 5V Supply (Common 0V required)

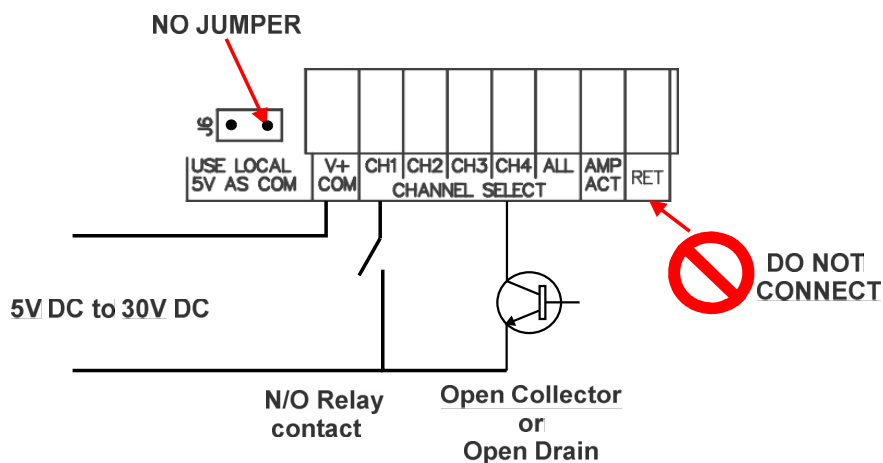

Figure 3: Using Isolated Supply

3. Speakers

The 100 Volt line outputs are supplied with a small DC bias voltage for the monitoring system (see below).

PA Speaker used with the Audio Distribution Module must be rated to 100 Vrms, and they must be fitted with a series capacitor to block the DC bias voltage. The capacitor must be bipolar and able to withstand 200 Volts (peak). The value should be approximately 1 μ F per watt of power for each speaker.

4. Cable Installation

A common problem of 100V line PA installations is the coupling of unwanted noise into the 100V line. Although the Audio Distribution Module has been designed to reduce the effects of coupled noise, it is recommended practice that all 100V line wiring be separated from ALL OTHER wiring by at least 250 mm. This includes Mains wiring, ELV wiring, Loop wiring and telephone wiring.

5. Audio Line Monitoring

The audio output lines are monitored using a small DC bias voltage to check for the presence of the EOL resistor. The monitoring is always active. It can detect short-circuit and open-circuit faults on the 100V line. The 100V line outputs must not be spurred. Each line must be terminated with a 47 k Ω , 0.5 W EOL resistor.

The DC bias voltage is floating with respect to ground and is DC-isolated from the '100 V Line In +' input. This allows a DC monitoring voltage to also be used on the input side of the ADM-4 (i.e. from the amplifier, monitoring the connection to the ADM-4) without the two monitoring systems interfering with one another.

6. Channel Isolation

Channels are individually turned OFF by opening a relay contact on the 100V line '+' rail only. The red 'ON' on each channel is an indication of whether this relay contact is open or closed, regardless of the channel selection settings.

7. Basic Connection – 4 Monitored Channels

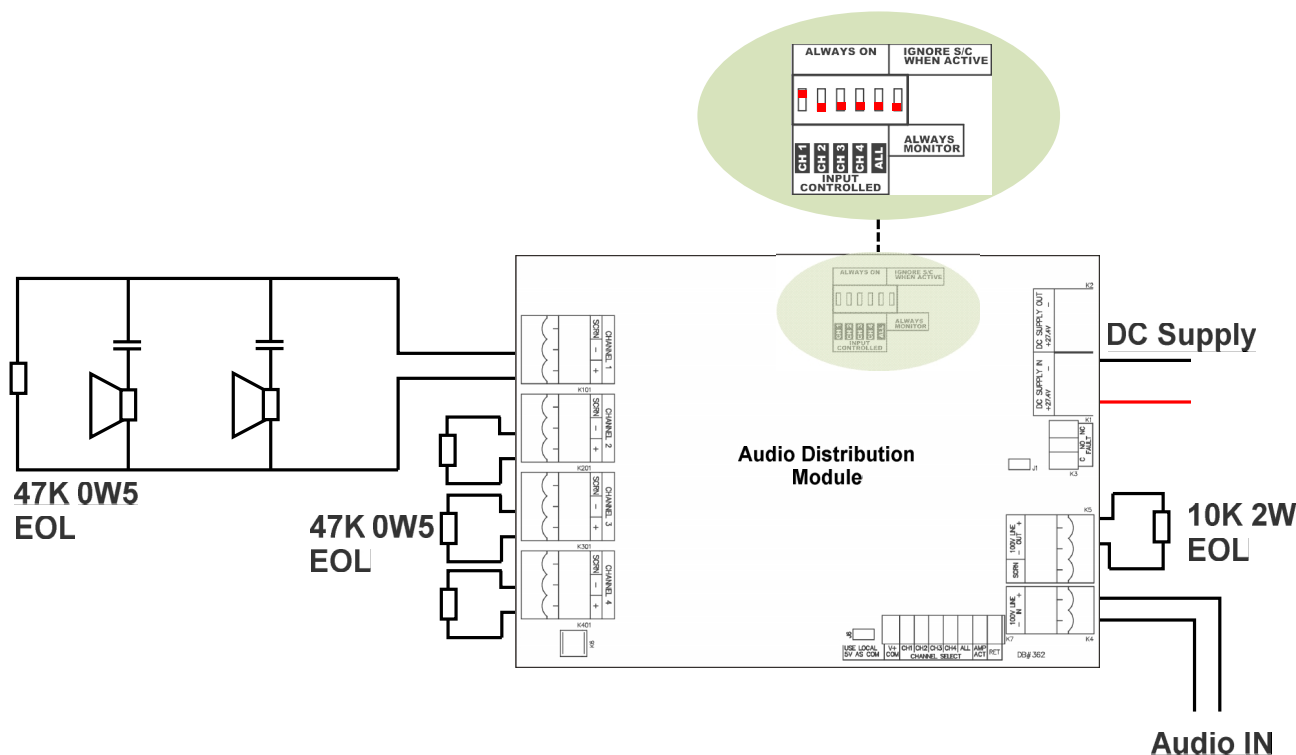

Figure 4: Basic Connection 4 Monitored Channels

8. Multiple Audio Distribution Modules

If more than four audio channels are required then multiple ADM-4 can be connected together.

The diagram below shows two modules connected to an amplifier.

An appropriate EOL resistor must be fitted to the 100V line on the last module. The value should be chosen to suit the audio source; in this example the EOL is a 10K 2W resistor.

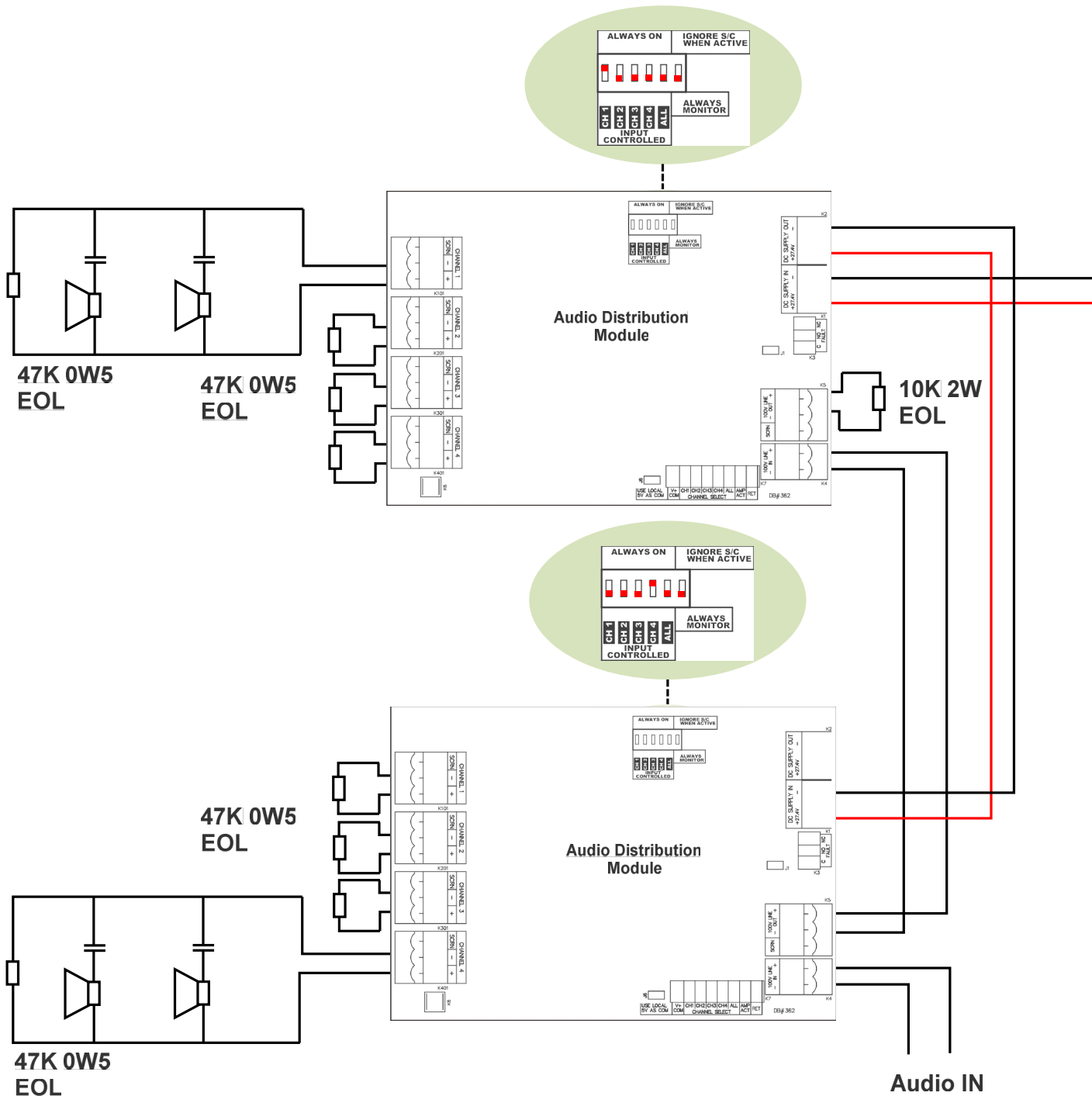

Figure 5: Multiple Audio Distribution Modules

9. Downstream Sub-Channel Activation

Sub-channels can be connected to any of the four output channels of the ADM-4 module.

A typical application using System Sensor M500S modules activated by an analogue addressable panel is shown in Figure 6 below.

Monitoring of the sub-channel speaker circuits is performed by the M500S module.

9.1 Audio Active Input (AMP ACT)

When sub-channels are operated their EOL resistance appears in parallel with the associated ADM-4 channel EOL.

Set the DIP switch “**IGNORE S/S WHEN ACTIVE**” to **ON** and connect the **AMP ACT** to an output from the tone generator or amplifier used. (“Amp Active Out” relay contacts from EVAC Generator or open Collector output via panel mapping for EVAC50W).

NOTE: Ensure DIP switch “**IGNORE S/S WHEN ACTIVE**” is **ON** and “**AMP ACT**” input is connected

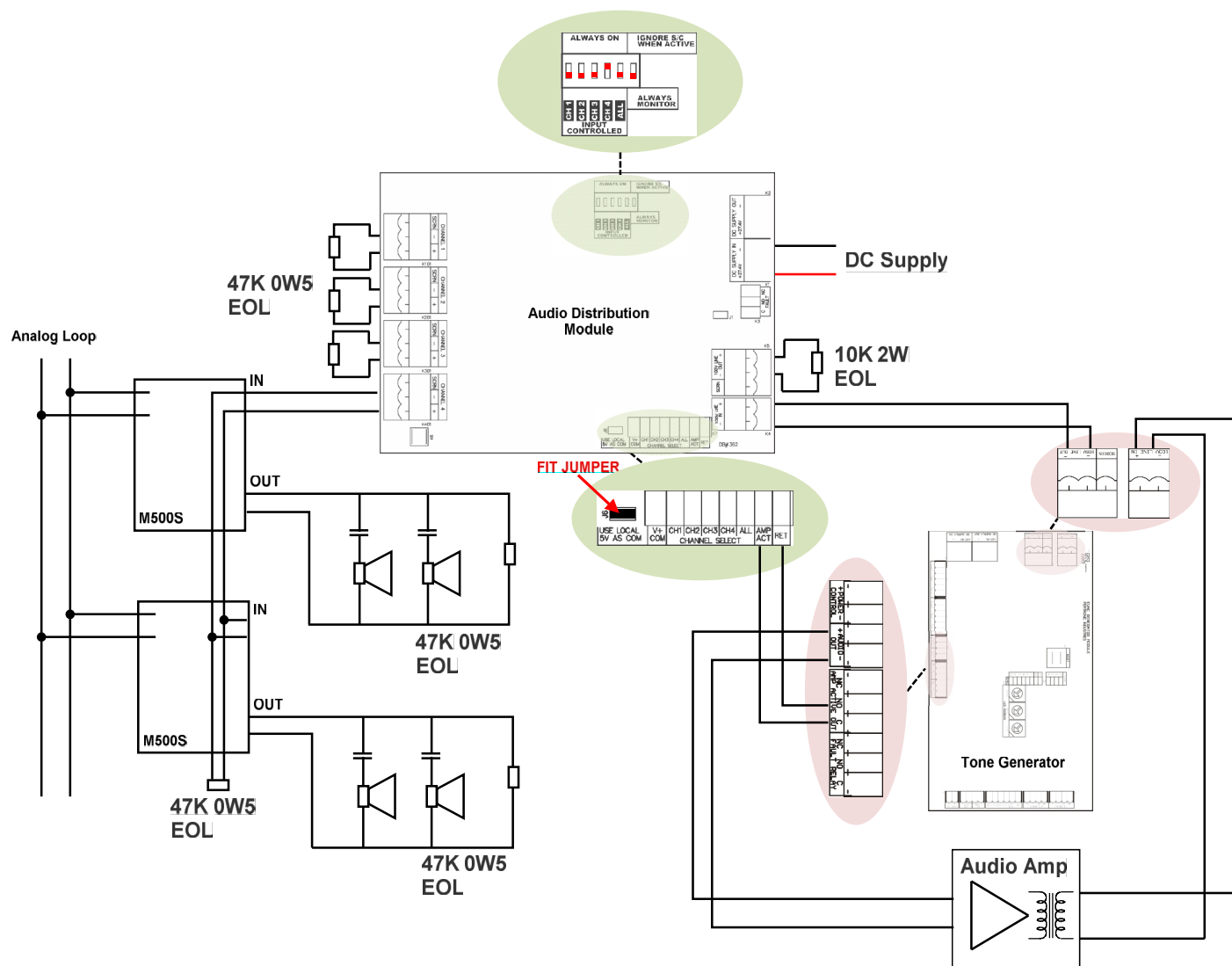

Figure 1: Downstream Sub-Channel Activation

Access Points:

Connectors	
Component	Description
K1	DC In
K2	DC Out
K3	Fault Relay
K4	100 V Line In
K5	100 V Line Out
K6	Earth Connection
K7	Amp Active, Channel Select
K101	Channel 1 100 V Line Out
K201	Channel 2 100 V Line Out
K301	Channel 3 100 V Line Out
K401	Channel 4 100 V Line Out

Jumpers		
Component	Not Fitted	Fitted
J1	No EOL Across Line In Fault Condition	6.8 k Ω EOL Across Line In Fault Condition
J6	Inputs Use Isolated V	Use Local 5 V

Switches	
Component	Description
SW1	Monitoring, Channel Select
SW2	Reset

Product Code	Description
ADM-4	Audio Distribution Module, 4-way