

**MODEL 6200 OPTICAL BEAM SMOKE DETECTOR**

ADDRESS CODING		DIGIT REQUIRED	Switch "8"	Switch "4"	Switch "2"	Switch "1"
SW10	UNITS	0	off	off	off	off
		1	off	off	off	on
		2	off	off	on	off
		3	off	off	on	on
		4	off	on	off	off
		5	off	on	off	on
		6	off	on	on	off
		7	off	on	on	on
	TENS	8	on	off	off	off
		9	on	off	off	on

**TABLE 1 - SETTING THE DEVICE ADDRESS ON A 6200**

Switch setting					Chosen sensitivity level	Relative sensitivity
SW5	SW4	SW3	SW2	SW1		Most sensitive = 1
off	off	off	off	on	maximum	1
off	off	off	on	off		1.3
off	off	on	off	off	medium	1.6
off	on	off	off	off		2.0
on	off	off	off	off	minimum	2.5
any other					Default (minimum)	2.5

**TABLE 2 - SENSITIVITY ADJUSTMENT**
**CAUTION**

Fire detection system components must be installed in accordance with the manufacturers stated operating parameters and with applicable recognised international and national standards or local codes of practice. Design, installation, commissioning and maintenance should be undertaken by competent organisations. Service should be undertaken on a regular basis in line with accepted codes of practice. Detection may not be effective if local conditions change or if equipment is not properly maintained. System sensor warrants this product to be free of manufacturing defects or component failure for three years from original supply but accepts no responsibility for claims of consequential loss as a result of such failures or defects. Defective product will be repaired or replaced when returned via the original distributor.

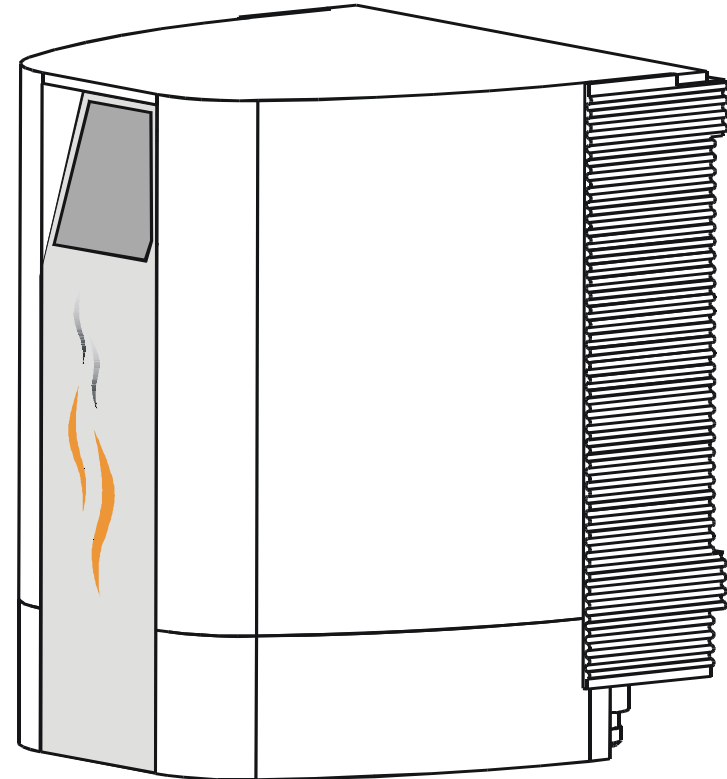

**MODEL 6200  
ANALOGUE ADDRESSABLE  
OPTICAL BEAM SMOKE DETECTOR**

**REFERENCES AND DESIGNATIONS**

Reference	Description
6200	Analogue Addressable Beam Detector
6200R	Conventional Linear Beam Detector with dry relay contact
REFL20	Short to medium range reflector
REFL30 / 40	Medium range reflectors
REFL50 / 60	Long range reflectors
6200-BR	Remote unit for 6200 (Refer to accessory data sheet)
6200-OBK	Orientation Bracket Kit (Refer to accessory data sheet)
6200-C	6200 Heater Pad Kit (Refer to accessory data sheet)
REFL20-C	REFL20 and REFL30 Heating pad kit (Refer to accessory data sheet)
REFL50-C	REFL 50 Heating pad kit (Refer to accessory data sheet)
6200 FILTER	Filter for alarm test

**GENERAL**

The 6200 is a reflector-type Linear Optical Beam smoke detector designed to operate as a component of an intelligent analogue addressable fire detection system, powered directly from the loop itself. The detector operates primarily on the principle of light obscuration, i.e. the alarm is triggered as a result of the change in the optical transmission of a beam of light beyond a set threshold.

The beam is designed to comply with the requirements of the draft European standard prEN54-12 (1998 edition) and is third party tested and approved to that standard.

The detector comprises two parts:

1. A unit containing all the electronics associated with the detector: Light Beam Emitter, Receiver, Signal Processing, and System Communication.
2. A high-efficiency reflector, which returns the light beam emitted.

**INSTALLATION RECOMMENDATIONS**

Installation should be undertaken in accordance with recognised international standards or required codes of practice. See the System Sensor "Guide for Proper Use of Projected Beam Smoke Detectors", reference I56-506, for installation guidelines. The following recommendations should also be taken into account:

**Note :** We recommend that simulated fire tests should be conducted to ensure that an adequate speed of response is achieved with the detector spacing utilised on each specific installation.

Height of premises (H)	Distance of beam to ceiling (D)	Area of effective detection (width from beam centre)
2.5 m ≤ H ≤ 5 m	0.3 ≤ D ≤ 0.5 m	5 m
5 m ≤ H ≤ 12 m	0.5 ≤ D ≤ 2 m	7 m

When designing the location and layout of the detectors, the following factors must be taken into account:

1. No obstruction should obscure the beam. The beam is narrow, but can move across the reflector. Make sure a cone of view is clear for the beam from the 6200, the base of which is at least equal to the overall dimension of the reflector.
2. Do not place the beam in a location where it may be interrupted by site activity (conveyor belts, fork lift trucks etc.), which can cause unwanted alarms and fault conditions.
3. Ensure the led indicators are clearly visible, unless a remote indicator or repeater unit has been provided.
4. Ensure freedom of access to the detector for installation and maintenance operations.
5. Do not expose the detector or its reflector to radiated light from other beams, or other intense sources of light.
6. It is critical that the transmitter/receiver part of the detector be installed on a rigid support, to prevent unwanted alarms and faults being triggered by structural movement of the building. The size of the reflector must be chosen in relation to the possible movement of the 6200 (see the curves on page 7 of this document). The reflector is not subject to the same restrictions.
7. Centre the red spot (visible when unit is switched to "installation" mode) emitted by the beam onto the reflector in order to provide for maximum tolerance to any structural movement of the building.
8. Install the 6200 onto an even vertical surface, which avoids any possible twisting of the termination box. Uneven mounting surfaces can create problems. If necessary, use an intermediate plate, or the optional mounting bracket (6200-OBK).
9. Use round headed screws (not countersunk), ø3.5 mm, to mount the termination box. The 6200 is light, so avoid excessive screw tightening which might stress the plastic termination box.

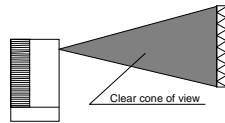

**ELECTRICAL SPECIFICATIONS**

PARAMETERS	6200
Power supply	Via intelligent loop (15 to 28 Vdc)
Power consumption in standby	3.2 mA at 20V
Power consumption in alarm mode	12 mA at 20V
Power consumption in fault mode	12 mA at 20V
Power consumption in contamination mode	12 mA at 20V
Power consumption in installation mode	< 40 mA at 20V
	Note: Set only one unit per loop to this mode simultaneously

**MECHANICAL SPECIFICATIONS**

PARAMETERS	6200
Weight	1 kg
Overall dimensions (mm)	195(h) x 155(l) x 150(w)
Protection number	IP42
Material	ABS
Colour	Grey, eggshell finish
Mounting	Screws at housing fixing points indicated
Cable termination	Via 5 knock-outs with appropriate cable glands

**CLIMATIC SPECIFICATIONS**

PARAMETERS	6200
Temperature	
• Operating	-10 to +55°C
• Storage	-20 to +70°C
Admissible relative humidity	
• Operating	< 95% non-condensing
• Storage	< 95% non-condensing

**OPTICAL SPECIFICATIONS**

PARAMETERS	6200	REFLEX 20	REFLEX 30 / 40	REFLEX 50 / 60
Range	10 to 100 m	10 to 30 m	30 to 50 m	30 to 100 m
Wavelength	670 nm (red)	-	-	-
Horizontal/Vertical adjustment	± 10° by 2 screws	none	None	none
Allowable movement during normal operation	Refer to graph below (*)	± 15°	± 15°	± 15°

(\*) The admissible movement of the beam depends on the range and the surface area of the reflectors.

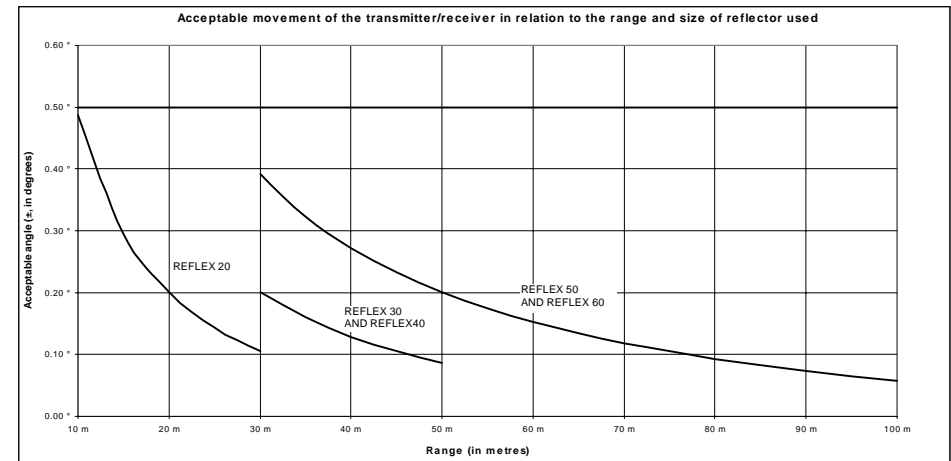

## FUNCTIONAL TESTS

### To test the fault condition

Completely obstruct the beam between the transmitter and reflector with a non-reflective material, such as a sheet of cardboard, for example. After approximately 20 seconds:

1. The yellow fault LED should light
2. A fault condition should be signalled to the control panel

Clear the obstruction from the beam path. After a few seconds:

1. The yellow fault LED should go out
2. The device returns to standby on the indicator panel

### To test the alarm condition

Obstruct the beam at or close to the transmitter/receiver unit, with one of the filters supplied, see Note: 2. Insert the filter into the path of the beam at an oblique angle (not perpendicular to the beam path) otherwise it may act as a reflector instead of an obscuration filter. After up to 30 seconds:

1. The red alarm led should light
2. An alarm condition should be signalled to the control panel

Remove the filter from the beam path, then reset at the control panel. After a few seconds:

1. The red alarm LED should go out
2. The device returns to standby on the indicator panel

Note: 2 filters are supplied, one green and one red. Depending on selected sensitivity and range, at least one filter should trigger an alarm condition whilst the other may cause a fault condition.

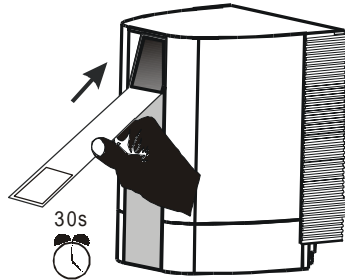

BEAM TEST FILTER

## OPERATION

### Standby condition

This is the normal status for the detector. No LED indicators should be lit.

### Alarm condition

The red alarm LED (under the 6200) is lit continuously. The alarm LED will remain lit until the unit is reset under command from the control panel.

On the control panel, the relevant visual and audible indicators will operate (see the instructions for the control panel):

1. Acknowledge the alarm signal
2. Follow the fire instructions
3. When the cause of the alarm has been investigated and resolved, reset the control panel, which resets the detector (and switches off the red LED).

### Fault condition

The cause of a fault may be due to:

1. **Obstruction / mis-alignment of the beam:** In this case, the yellow fault LED is turned on steady. To return to standby status remove the obstruction or re-align to ensure the path of the beam remains clear to the reflector.
2. **Incorrect start-up or detector failure:** This fault occurs immediately after exiting the installation mode. The yellow fault LED illuminates continuously. The installation procedure should be repeated and all parameters checked for this fault to be cancelled.
3. **Excessive contamination of the optical parts:** The yellow fault led flashes. The 6200 is capable of compensating the signal for contamination up to a preset limit. Carefully wipe the beam window and the reflector surface clean with a damp cloth then revert to installation mode to check signal strength and beam alignment. The detector should then return to standby.

On the control and indicating panel, the relevant visual and audible warnings are triggered.

1. Acknowledge the warning signals
2. Go to the zone related to the fault condition and identify the possible cause
3. Inform service personnel, and follow the agreed safety procedures for the installation.

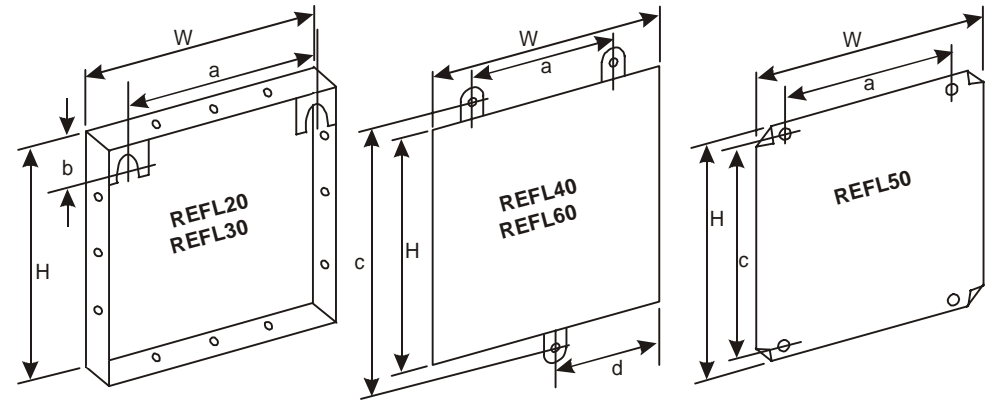

	H (mm)	W (mm)	a (mm)	b (mm)	c (mm)	d (mm)	Weight g	Material	Colour
REFL20	205	205	180	14	-	-	520	Al	Grey
REFL30	305	305	280	14	-	-	1100	Al	Grey
REFL40	400	400	201	-	427	200	1226	ABS	Grey
REFL50	548	508	450	-	530	-	3600	Al	Grey
REFL60	600	600	392	-	630	300	1600	ABS	Grey

## INSTALLATION MOUNTING LIMITS

Internal adjustment of the optical assembly within the 6200 housing allows the beam to be installed on flat surfaces, inclined up to 10° from the required beam path. Similarly the reflector can accommodate an offset of up to 15° from the beam path. If the angle is greater than those indicated, use the 6200-OBK orientation bracket kit for improved alignment.

## ALIGNMENT RECOMMENDATIONS

The model 6200 offers significant set-up advantages by providing easy alignment when using the "installation" mode, which generates a visible targeting spot of light. However when setting up at distances greater than 50 meters:

1. Try to choose the time of installation when the (natural) lighting in the premises is reduced to emphasise spot intensity
2. Use structural elements (ceilings, girders, partitions etc.) to identify the trajectory of the beam. If necessary, use a large-dimension back-up reflector surface to aid the alignment with the final installed reflector.

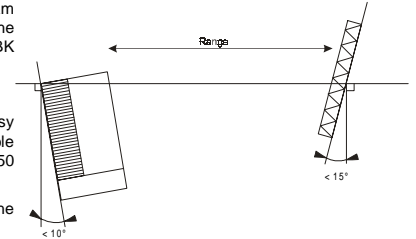

## EXAMPLE

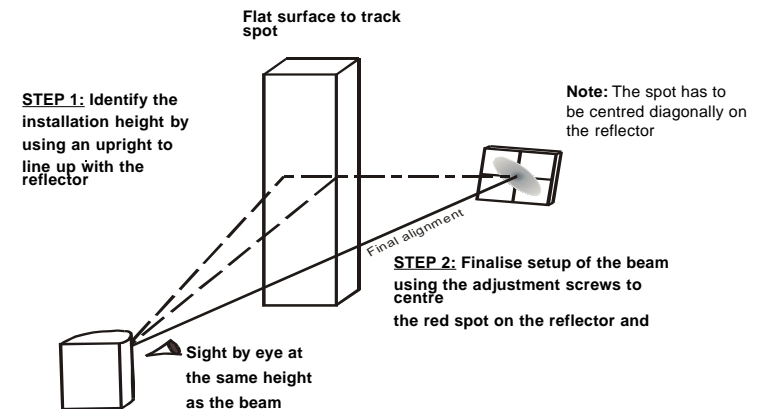



**INSTALLATION**

It is recommended to use the following steps for set-up:

- A. Disassemble the beam as shown
- B. Mount securely to a fixed vertical surface
- C. Connect field wiring and assemble optical module
- D. Set the switch configuration as required
- E. Connect system loop wiring to panel and apply power
- F. Engineers switch - set to "installation" position
- G. Align beam and centre on reflector
- H. Assemble housing cover
- I. Engineers switch - set to "operating" position
- J. Close the bottom access door



Alarm conditions may be generated during the set-up phase thus the control panel should be switched to engineering mode with outputs isolated until beam detector commissioning has been completed.

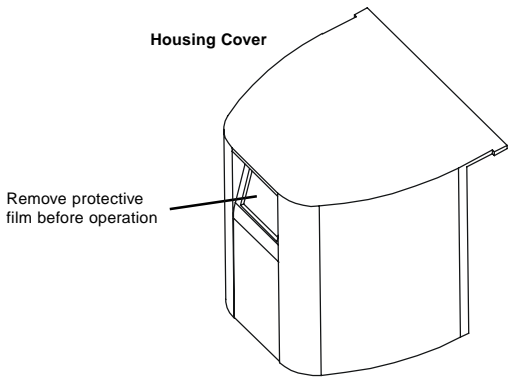

**D. SWITCH CONFIGURATION**

Standard (sensitivity) settings recommended

Level 1 or 2, the fastest detection, and the most sensitive, for areas subject to rapid air movement

Level 4 or 5, the least sensitive, and the slowest response, for areas with higher contamination (e.g. dust, condensation), or long beam lengths (<70m)

**Do not select several switches at once otherwise minimum sensitivity is adopted by default; refer to TABLE 2**

**Set the unit address**

The address is set in the range 01-99 according to the coding scheme indicated in TABLE 1 and inside the 6200 housing cover.

**E. CONNECT TO PANEL AND APPLY POWER**

**A. DISASSEMBLE MAJOR COMPONENTS**

Remove housing cover by releasing captive screw (shown X), then release spring clip (shown Z) allowing the housing to be pulled apart. Carefully separate optical assembly from rear termination box after releasing captive screws (shown Y) and disconnecting plugs from sockets marked J1, J2 and B1 on the termination PCB.

**B. FIX TO VERTICAL SURFACE**

Maintain minimum clearance distances around beam as indicated in diagram above. Ensure termination back box is fixed securely to a rigid vertical surface directly opposite to the mounted reflector. Do not distort the box moulding by over-tightening fixing screws. (Note: an adjustable mounting bracket is available if required as a special order accessory).

**C. CONNECT FIELD WIRING AND REFIT OPTICAL MODULE**

Terminate cables through knock-outs provided in bottom plate (use glands provided or compatible alternatives)

Connect to terminals in accordance with details shown.

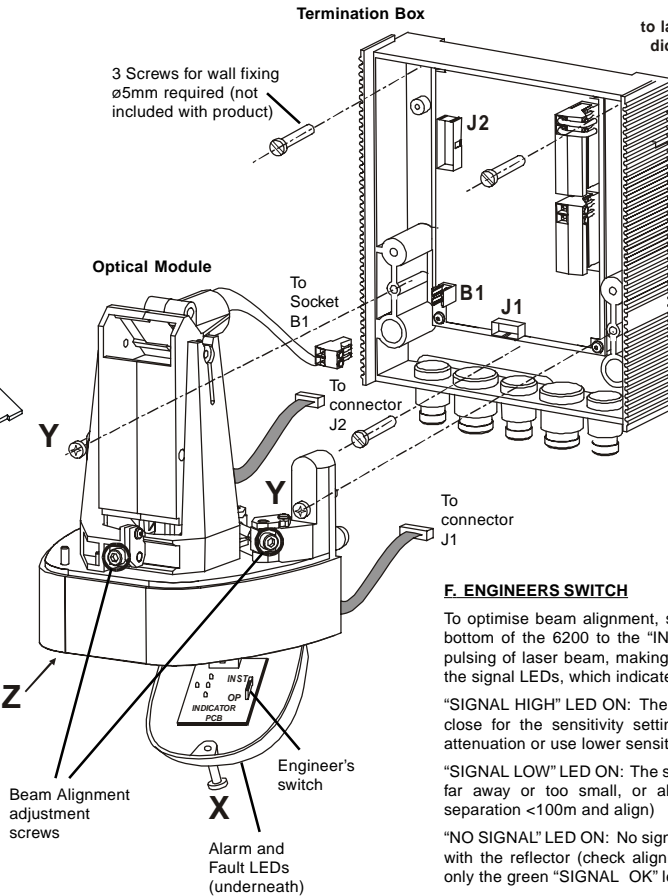

Beam Alignment adjustment screws

Alarm and Fault LEDs (underneath)

Termination Box

3 Screws for wall fixing  $\varnothing 5\text{mm}$  required (not included with product)

Remove protective film before operation

Housing Cover

Optical Module

To Socket B1

To connector J2

To connector J1

**F. ENGINEERS SWITCH**

To optimise beam alignment, set switch SW1 on the Indicator PCB at the bottom of the 6200 to the "INSTALLATION" position. This provides rapid pulsing of laser beam, making visible adjustment easy, in conjunction with the signal LEDs, which indicate the following:

"SIGNAL HIGH" LED ON: The signal is saturated; the reflector must be too close for the sensitivity setting (fit cover onto beam as it adds a little attenuation or use lower sensitivity setting)

"SIGNAL LOW" LED ON: The signal received is too weak, the reflector is too far away or too small, or alignment is not correctly adjusted (ensure separation <100m and align)

"NO SIGNAL" LED ON: No signal detected, the beam is not correctly aligned with the reflector (check alignment). When the beam is aligned correctly only the green "SIGNAL OK" led should be on.

**G. BEAM ALIGNMENT AND CENTERING ONTO REFLECTOR**

Accurate adjustment of the beam may be made in both the vertical and horizontal planes by use of the two adjustment screws indicated (use hex Allen key/wrench no.8). Ensure the focus of the beam is central on the reflector.

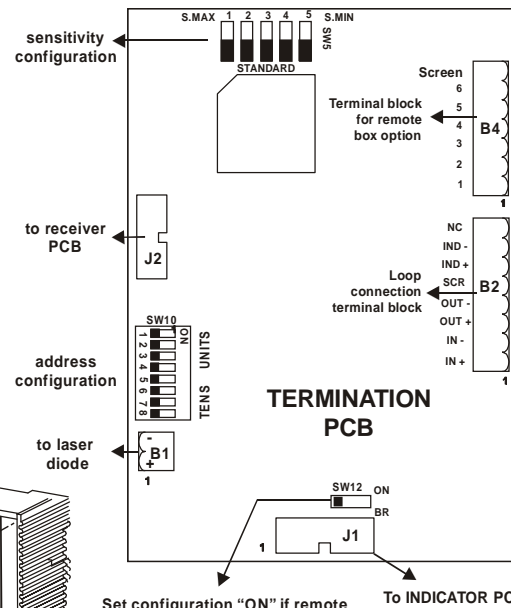

Set configuration "ON" if remote indicator box is connected, otherwise leave set to "OFF"

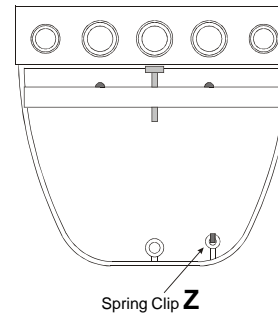

Spring Clip Z

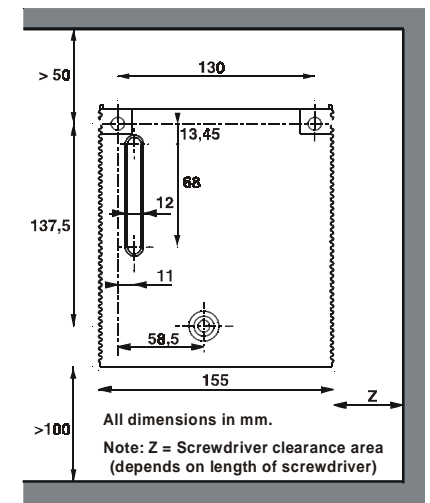

All dimensions in mm.  
Note: Z = Screwdriver clearance area (depends on length of screwdriver)

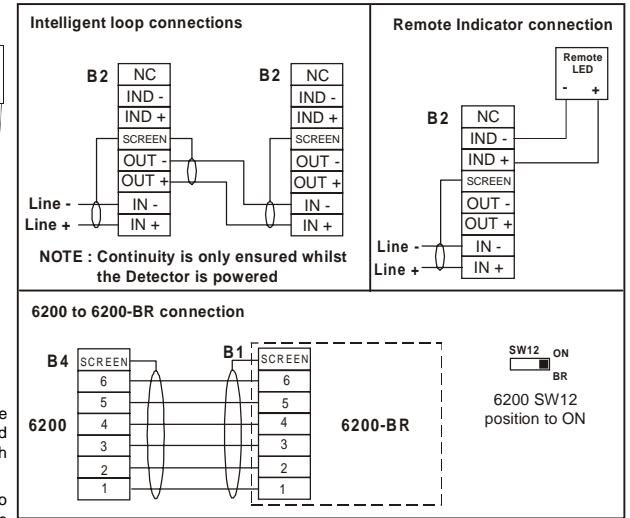

**6200 to 6200-BR connection**

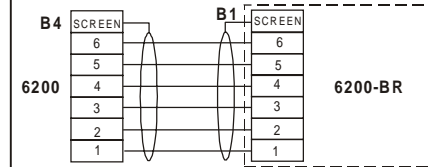

**H. COVER INSTALLATION**

Replace the housing cover, ensuring that the spring clip Z is securely latched into position.

**I. ENGINEERS SWITCH - NORMAL OPERATION**

Only return the Indicator PCB switch SW1 to the "operating" position when the cover is correctly refitted. The green led should light up for a few seconds (do not disturb the beam during this time). All indicators should be off in the normal monitoring state.

**J. CLOSE THE BOTTOM ACCESS DOOR**

Close the lower Indicator PCB door and fix using the captive screw marked X.